

Mark 37/377 Series

Final Control Element

The Mark 37 is a motor-operated control valve that combines a state-of-the-art electronic linear actuator with the exceptional performance of Jordan's sliding gate valve seat design. The result is a superior degree of accuracy that makes the Mark 37 ideal for use as the final control element in distributed process control systems.

Precision control begins with a high resolution, low hysteresis digitally controlled motor. Additional features include a switch selectable power supply, a hand drive mechanism for manual operation, and a 4-20 mA current input signal. Upon loss of signal (not loss of power), the motor is designed to lock in place or fail to the minimum input signal position.

Accuracy is further enhanced through the use of Jordan's unique sliding gate valve seat. Consisting of a modulating disc and stationary plate, the seat components are slotted with multiple orifices that align to provide the precise flow needed to meet the control system requirements. With multiple openings distributed over the mass of the seating surfaces, the valve fully strokes in a fraction of the travel required by conventional valves, for rapid correction of any deviation from the process setpoint.

FEATURES

- Sliding Gate Seats — all of Jordan Valve's differential regulators feature advanced sliding gate seat technology.
 - Straight-through flow reduces turbulence for long life, quiet operation and excellent rangeability
 - Short stroke for fast response and accurate regulation.
 - Interchangeable seats for easy maintenance and Cv changes
 - Tight Shutoff (ANSI Class IV) due to overlap of seat closure area
- A stroke shorter than those found in globe or plug-style valves results in an operation much faster than other electric control valves.
- Long packing and stem life, with stem packing four times deeper than stem travel.
- Fewer spare parts, no gaskets or o-rings (on sizes 2" and below), and self cleaning seats mean long valve life and easy maintenance.

ALTERNATIVE MODELS

For customers who require the specifications and performance of the Mark 37, but require equal percentage seats, Jordan Valve offers the MK377.



SPECIFICATIONS

Sizes: 1/4" through 6" (DN8 through DN150)

Note: 1/4" & 3/8" sizes uses 1/2" body with reducers

End Connections:

- Threaded (NPT, BSPT, BSPP – through 2" sizes)
- ANSI Flanges (150#, 300#)
- DIN Flanges (PN10/16, PN25/40)

Body Materials:

- Bronze (1/2" - 2"/DN15-DN50)
- Ductile Iron
- Carbon Steel (WCB)
- Stainless Steel (CF8M)

Trim Materials:

- 303SS for DI, BZ or CS valves
- 316SS for SS body valves

Seat Materials:

- 303 SST/Jorcote
- 316 SST/Jorcote

Yoke Material: Cast Iron

Stem Packing:

- Spring-loaded Teflon (500°F max/260°C)
- Braided (above 500°F/260°C)

Service: steam, water, air, oil, gas and chemicals

Shutoff: ANSI Class IV

Flow Characteristic:

- Linear
- Equal percentage (specify model MK377)

Action:

- Direct (control signal closes valve)
- Reverse (control signal opens valve)

Actuators:

- CML 100 Maximum Thrust 100 lb. (0,4 Kn)
- CML 250 Maximum Thrust 250 lb (1,1 Kn)
- SM1100 - for valves 2-1/2" - 6" in size

Cv (Kv) Values and Maximum Allowable ΔP Ratings

Size (DN)	Cv (Kv)	Seat Material	Maximum ΔP psi (bar)	
			MK37	MK377
1/2" & 3/4" (DN15 & 20)	2.5 (2,15)	SST	125 (8,62)	N/A
	4.4 (3,78)	Jorcote	250 (17,24)	N/A
1/2" (DN15)	2.5 (2,15)	Jorcote	N/A	250 (17,24)
3/4" (DN20)	4.4 (3,78)	Jorcote	N/A	150 (10,34)
1" & 1-1/4" (DN25 & 32)	6.4 (5,50)	SST	100 (6,89)	N/A
	9.5 (8,17)	Jorcote	150 (10,34)	N/A
1" (DN25)	11.5 (9,89)	SST	N/A	100 (6,89)
		Jorcote	N/A	150 (10,34)
1-1/4" (DN32)	13 (11,2)	SST	N/A	100 (6,89)
		Jorcote	N/A	150 (10,34)
1-1/2" (DN40)	15 (12,9)	SST	75 (5,17)	100 (6,89)
		Jorcote	125 (8,62)	150 (10,34)
1-1/2" (DN40)	22 (18,9)	SST	N/A	100 (6,89)
		Jorcote	N/A	150 (10,34)
2" (DN50)	25 (21,5)	SST	75 (5,17)	N/A
	30 (25,8)	Jorcote	125 (8,62)	N/A
2" (DN50)	34 (29,2)	SST	N/A	100 (6,89)
		Jorcote	N/A	150 (10,34)
2-1/2" (DN65)	60 (51,6)	Jorcote	N/A	80 (5,52)
3" (DN80)	80 (68,8)	Jorcote	N/A	80 (5,52)
2-1/2" (DN65)	85 (73)	Jorcote	250 (17,34)	N/A
3" (DN80)	130 (112)	Jorcote	200 (13,79)	N/A
4" (DN100)	200 (172)	Jorcote	150 (10,34)	N/A
6" (DN150)	230 (197,8)	Jorcote	N/A	50 (3,45)
6" (DN150)	395 (340)	Jorcote	50 (3,45)	N/A

For smaller Cv (Kv) values, consult the factory.

MOTOR SPECIFICATIONS

Please see page 3 for specific information on CML100 motor.

- Adjustable speed
- Limit switches
- Selectable failure mode
- Manual operation by hand knob

MOTOR SPECIFICATIONS

CML 100 Motor: 1/4" - 2" Valves (DN8-50)



SM1100 Motor: 2-1/2" - 6" (DN65-150)

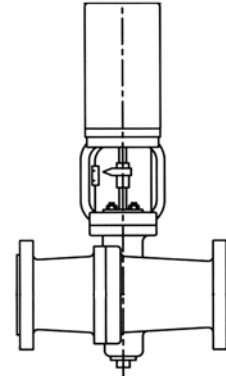

Electrical

- Line Voltage: 120/240 VAC (switch selectable) & 24 VDC (contact factory)
- Conduit Entry: two 3/4" NPT or M25
- Frequency: 50/60 Hz
- Current: 0.06 / 0.49 @ 120 VAC
- Command Signal input:
 - Current: 4-20 mA
 - Optional control methods available upon request
- Optional Supercapacitor Power Backup

Mechanical

- Max thrust:
 - CML 100: 100 lb. (0,4 Kn)
 - CML 250: 250 lb. (1,1 Kn)
- Speed:
 - CML 100: 0.125 to 0.25"/sec (3,18 - 6,4mm/sec)
 - CML 250: 0.065 to 0.13"/sec (1,59 - 3,18mm/sec)
- Action: direct or reverse

Environmental

- Temperature Limits:
 - CML 100: -4°F to +150°F (-20°C to +66°C)
 - CML 250: -4°F to +150°F (-20°C to +66°C)
 - Optional low temperature trim for CML motors: -40°F to +150°F (-40°C to +66°C)
- Enclosure:
 - Explosion-proof for Class I, Div. 1, Group C&D
 - Dust-ignition-proof for Class II, Div. 1, Group E, F, G
 - CML 100 / CML 250: NEMA 4 & 6 (IP67), indoor or outdoor
- Approvals
 - CML 100 / CML 250: ATEX, FM, CSA (excluding supercapacitor backup and local controls)

Electrical

- **120VAC**, Single Phase Modulating Duty
 - Running Current: 0.27 amps
 - Frequency: 50/60 Hz
 - Stall Current: 0.31 amps
- **24VDC**, Permanent Magnet, Modulating Duty
(Note: internal amplifier uses 24VDC power supply; external amp requires 115VAC power supply)
 - Running Current: 1.2 amps
 - Stall Current: 4.8 amps

Control Signal

- Standard Input Signal: on/off
- Optional Input Signals (requires amplifier)
 - Resistance Command: 0-1000 ohms
 - Current Command: 1-5mA DC; 4-20mA DC; 10-50mA DC; split ranges upon request
 - Voltage Command: 0-24VDC; 0-10VDC

Motor Enclosures

- Temperature Limits: -40°F to 150°F (-40°C to 65°C)
- Standard: NEMA 12 – inside industrial
- Optional: *Explosion-proof* for Class I, Div. I, Group C & D; *Dust-ignition-proof* for Class II, Div. I, Group E, F, G; Type 4 (IP65), indoor or outdoor (optional)

Amplifier Enclosures (Optional)

- NEMA 12: inside industrial; NEMA 4: water-tight; NEMA 7 & 9: explosion-proof. Note: internal amplifiers are available for AC motor in 4-20mA; for DC motors in 4-20mA or 0-10 VDC; panel-mounted amplifier also available. Internal amplifiers require NEMA 4 or 7/9 motor enclosures.

Net Loading Effect on Electronic Controller

- 2700 ohms (1-5mA)
- 470 ohms (4-20mA)
- 270 ohms (10-50mA)

FLOW CHART FOR MARK 37

Valve Size	Cv at Travel										
	10%	20%	30%	40%	50%	60%	70%	80%	90%	100%	F _L
1/2" & 3/4" (DN15 & DN20)	0.290	0.520	0.740	0.960	1.200	1.450	1.820	2.160	2.340	2.50	0.80
	0.580	0.890	1.270	1.580	1.930	2.480	3.020	3.540	4.090	4.40	0.77
1" & 1-1/4" (DN25 & DN32)	0.970	1.460	1.920	2.500	3.170	3.870	5.180	5.700	6.310	6.40	0.75
	1.240	2.000	2.710	3.490	4.360	5.300	6.360	7.280	9.340	9.50	0.72
1-1/2" (DN40)	1.390	2.490	3.680	4.760	6.140	7.850	10.30	13.10	14.60	15.0	0.69
2" (DN50)	2.580	4.340	6.210	8.470	10.80	13.80	18.30	22.70	24.80	25.0	0.67
	1.950	3.900	6.300	8.460	11.10	14.20	18.20	25.90	29.10	30.0	0.66

FLOW CHART FOR MARK 377

2.5 Cv - Equal Percentage

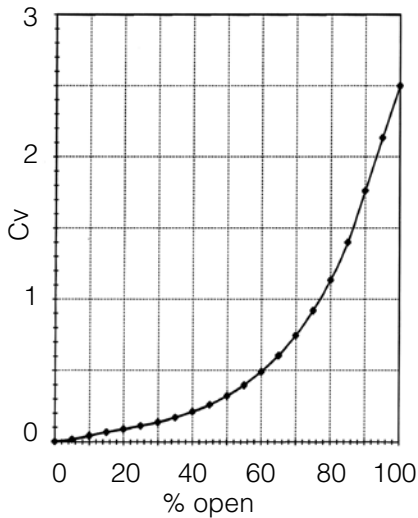

4.4 Cv - Equal Percentage

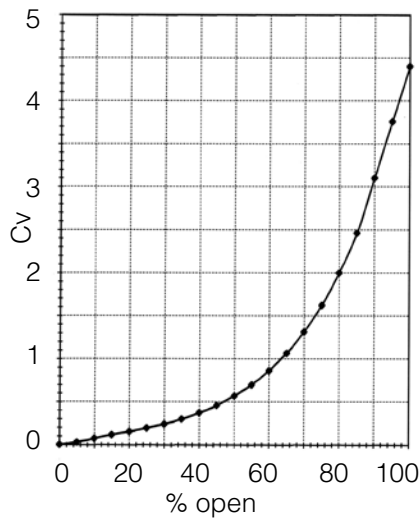

11.5 Cv - Equal Percentage

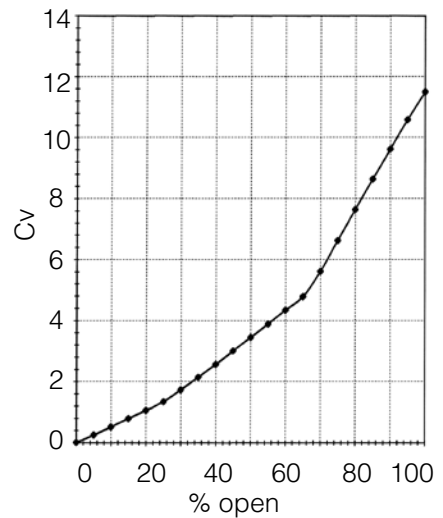

13 Cv - Equal Percentage

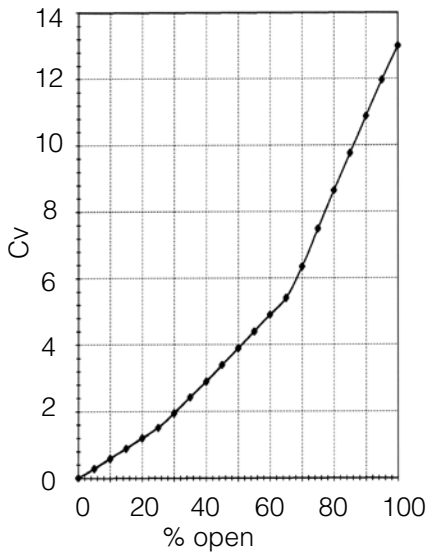

22 Cv - Equal Percentage

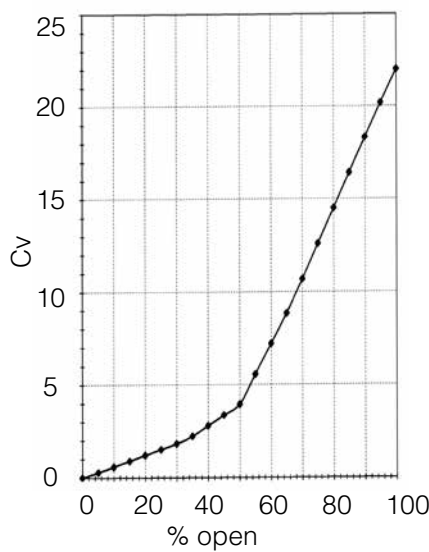

34 Cv - Equal Percentage

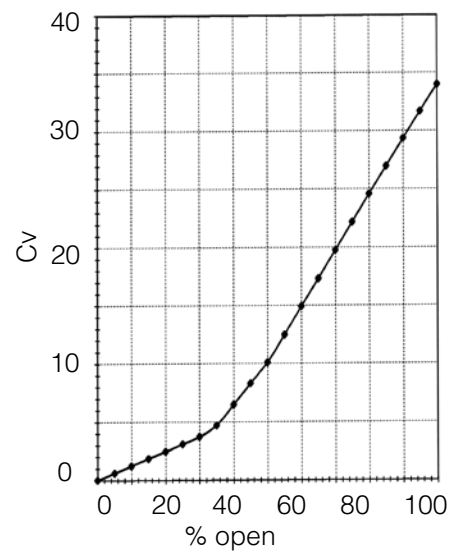

MARK 37/377 ELECTRIC MOTOR OPERATED FINAL CONTROL ELEMENT

DIMENSIONS

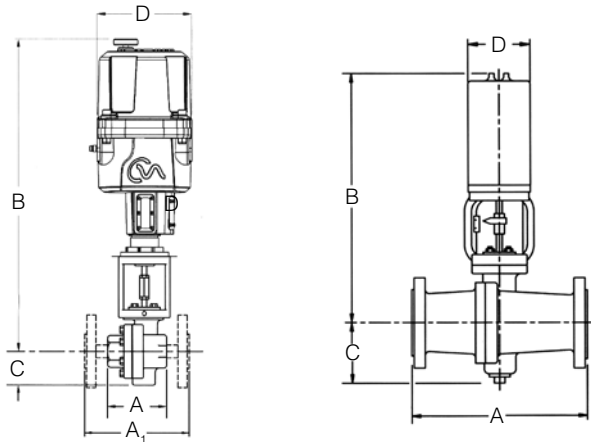

• Threaded & FSW Ends 1/2" - 2"

Size	Mat'l	Dimensions (inches)				Weight (lbs.)
		A	B*	C**	D	
1/2" & 3/4"	DI/BRZ	3.62	19.51	2.12	7.09	22
	CS/SS	3.65	19.51	2.18	7.09	23
1"	DI/BRZ	4.12	19.79	2.62	7.09	24
	CS/SS	4.25	19.79	2.62	7.09	25
1-1/4"	DI/BRZ	4.12	19.79	2.62	7.09	24
1-1/2"	DI/BRZ	4.50	20.01	2.62	7.09	25
	CS/SS	4.65	20.01	2.75	7.09	26
2"	DI/BRZ	4.50	20.13	2.62	7.09	27
	CS/SS	5.50	20.13	3.00	7.09	30

• Flanged Ends, 1/2" - 2"

Size	Flange	Dimensions (inches)				Weight (lbs.)
		A1	B*	C**	D	
1/2"	150#	7.25	19.51	2.18	7.09	24
	300#	7.50	19.51	2.18	7.09	27
3/4"	150#	7.25	19.51	2.18	7.09	26
	300#	7.62	19.51	2.18	7.09	29
1"	150#	7.25	19.79	2.62	7.09	29
	300#	7.75	19.79	2.62	7.09	31
1-1/4"	150#	7.87	19.79	2.62	7.09	28
	300#	8.37	19.79	2.62	7.09	32
1-1/2"	150#	8.75	20.01	2.75	7.09	31
	300#	9.25	20.01	2.75	7.09	38
2"	150#	10.00	20.13	3.00	7.09	37
	300#	10.50	20.13	3.00	7.09	34

• Threaded & FSW Ends, DN15 - DN50, Metric

Size (DN)	Mat'l	Dimensions (mm)				Weight (kg)
		A	B*	C**	D	
15 & 20	DI/BRZ	92	495,5	55	180,1	10,0
	CS/SS	93	495,5	55	180,1	10,4
25	DI/BRZ	105	502,6	67	180,1	10,9
	CS/SS	105	502,6	67	180,1	11,3
32	DI/BRZ	105	502,6	67	180,1	10,9
40	DI/BRZ	114	508,2	67	180,1	11,3
	CS/SS	118	508,2	70	180,1	11,8
50	DI/BRZ	114	511,3	67	180,1	12,2
	CS/SS	140	511,3	76	180,1	13,6

• Flanged Ends, DN15 - DN50, Metric

Size	Flange (PN)	Dimensions (mm)				Weight (kg)
		A1	B*	C**	D	
15	10/16	130	495,5	55	180,1	10,9
	25/40	130	495,2	55	180,1	12,2
20	10/16	150	495,5	55	180,1	11,8
	25/40	150	495,5	55	180,1	13,2
25	10/16	160	502,6	67	180,1	13,2
	25/40	160	502,6	67	180,1	14,1
32	10/16	180	502,6	67	180,1	12,7
	25/40	180	502,6	67	180,1	14,5
40	10/16	200	508,2	70	180,1	14,1
	25/40	200	508,2	70	180,1	17,2
50	10/16	230	511,3	76	180,1	16,8
	25/40	230	511,3	76	180,1	20,0

• Flanged Ends, 2-1/2" - 6"

Size	Flange	Dimensions (inches)				Weight (lbs.)
		A	B*	C**	D	
2-1/2"	125-150#	10.88	26.22	5.84	4.50	175
	250-300#	11.50	26.22	5.84	4.50	175
3"	125-150#	11.75	26.22	5.84	4.50	190
	250-300#	12.50	26.22	5.84	4.50	190
4"	125-150#	13.88	28.54	6.91	4.50	300
	250-300#	14.50	28.54	6.91	4.50	300
6"	125-150#	17.75	30.10	7.72	4.50	375
	250-300#	18.62	30.10	7.72	4.50	375

• Flanged Ends, 2-1/2" - 6"

Size (DN)	Flange (PN)	Dimensions (mm)				Weight (kg)
		A	B ₁	C	D ₂	
65	10/16	287	666	148	114	79
	25/40	293	666	148	114	79
80	10/16	313	666	148	114	83
	25/40	313	666	148	114	83
100	10/16	353	725	176	114	136
	25/40	353	725	176	114	136
150	10/16	474	765	196	114	170
	25/40	474	765	196	114	170

* An additional 5-3/4" is needed to remove motor cover from electrical connections

* CML 100 & CML 250 have same mounting dimensions

1 Add 160 mm for removal of motor cover for electrical connections

-5- 2 For explosion-proof motor, add 8,38 mm to Dimension 'D'

ORDERING SCHEMATIC

To specify a MK37/377 Final Control Element, build a model number by making a selection from each category in the Product Designator Coding System below.

1	—	2	—	3	/	4	5	6	7	8	9	10	11

1	Model	
37	Standard	
377	Equal Percentage Version	

2	Size				
	Inches	DN		Inches	DN
025	1/4"	DN8	150	1-1/2"	DN40
038	3/8"	DN10	200	2"	DN50
050	1/2"	DN15	250	2-1/2"	DN65
075	3/4"	DN20	300	3"	DN80
100	1"	DN25	400	4"	DN100
125	1-1/4"	DN34	600	6"	DN150

3	Material	
DI	Ductile Iron	
BR	Bronze	
CS	Carbon Steel (WCB)	
S6	Stainless Steel (CF8M)	
CI	Cast Iron	

4	End Connections			
PT	NPT	F5	150# FE (except IFE)	
BT	BSPT	I2	250# IFE	
BP	BSPP	F2	250# FE (except IFE)	
SW	FSW	I3	300# IFE	
I1	125# FE	F3	300# FE (except IFE)	
F1	125# FE (except IFE)	ZZ	Non-Standard	
I5	150# IFE			

5	Trim	
T3	303SS/Teflon Packing, On-Off	
T6	316SS/Teflon Packing, On-Off	
V3	303SS/Teflon Packing, Ma/Volt	
V6	316SS/Teflon Packing, Ma/Volt	
ZZ	Non-Standard	

6	Seat Materials	
V	303SS/Jorcote	
W	316SS/Jorcote	

7	Seat Cv (Kv)		
		MK37	MK377
1	0.21 (0,18)	5	2.5 (2,16)
2	0.42 (0,36)	6	4.4 (3,78)
3	0.84 (0,72)	N	11.5 (9,91)
4	1.6 (1,38)	P	13 (11,2)
5	2.5 (2,16)	S	22 (18,9)
6	4.4 (3,78)	U	34 (29,3)
7	6.4 (5,51)	I	60 (51,7)
8	9.5 (8,18)	2	80 (68,9)
9	15 (12,9)	H	130 (112,1)
A	25 (21,5)	3	230 (198,2)
B	30 (25,8)	ZZ	Non-Standard
F	85 (73)		
H	130 (112)		
I	200 (172)		
J	395 (340)		

8	Range		
		1/4" - 2"	2-1/2" - 6"
NF	On-Off	IA	Internal Amp
42	4-20mA	NF	On-Off
41	4-12mA	42	4-20mA Ext. Amp.
12	12-20mA	A4	1-5mA Ext. Amp.
V5	0-5V	A5	10-50mA Ext. Amp.
V1	0-10V	A6	0-10/0-5V Ext Amp.
ZZ	Non-Standard		

9	Actuator		
		1/4" - 2"	2-1/2" - 6"
C1	Act/Yoke CML100 AC All Range	IA	Int. Amp. 4-20mA X-P/Nema 4
C2	Act/Yoke CML250 AC All Range	NF	On-Off or Ext. Amp. Nema 12
		XP	On-Off or Ext. Amp. X-P
ZZ	Non-Standard		

10	Accessories	
SC	Clean for Oil Free Service	
XC	Clean for Oxygen Service	
02	Set Motor for 240 VAC	
ZZ	Non-Standard	

11	Action	
DD	Direct	
RR	Reverse	

