

# FlatTrak™ 780S Series Mass Flow Meter

Including 760S Kynar



## Instruction Manual

Part Number IM-78S  
Revision O, August 2018



### **CORPORATE HEADQUARTERS**

5 Harris Court, Building L Monterey, CA 93940  
Phone (831) 373-0200 (800) 866-0200 Fax (831) 373-4402  
[www.sierrainstruments.com](http://www.sierrainstruments.com)

### **EUROPE HEADQUARTERS**

Bijlmansweid 2 1934RE Egmond aan den Hoef  
The Netherlands  
Phone +31 72 5071400 Fax +31 72 5071401

### **ASIA HEADQUARTERS**

Second Floor Building 5, Senpu Industrial Park  
25 Hangdu Road Hangtouw Town  
Pu Dong New District, Shanghai, P.R. China  
Postal Code 201316  
Phone: + 8621 5879 8521 Fax: +8621 5879 8586

### **IMPORTANT CUSTOMER NOTICE- OXYGEN SERVICE**

Sierra Instruments, Inc. is not liable for any damage or personal injury, whatsoever, resulting from the use of Sierra Instruments standard mass flow meters for oxygen gas. You are responsible for determining if this mass flow meter is appropriate for your oxygen application. You are responsible for cleaning the mass flow meter to the degree required for your oxygen flow application.

### **© COPYRIGHT SIERRA INSTRUMENTS 2018**

No part of this publication may be copied or distributed, transmitted, transcribed, stored in a retrieval system, or translated into any human or computer language, in any form or by any means, electronic, mechanical, manual, or otherwise, or disclosed to third parties without the express written permission of Sierra Instruments. The information contained in this manual is subject to change without notice.

### **TRADEMARKS**

FlatTrak™, SteelTrak™ and Smart Interface™ software are trademarks of Sierra Instruments, Inc. Other product and company names listed in this manual are trademarks or trade names of their respective manufacturers.

All Sierra products are Year 2000 compliant.

---

# Table of Contents

## Chapter 1 Introduction

FlatTrak 780S Series Mass Flow Meters .....	1-1
Using this Manual .....	1-1
Note and Safety Information.....	1-2
Receipt of System Components .....	1-2
Technical Assistance.....	1-2
The Series 780S Flow Sensing Principle .....	1-3
Smart Electronics Features .....	1-4
Enclosure Options.....	1-5
Smart Interface™ Software.....	1-5

## Chapter 2 Installation and Wiring

Installation Overview .....	2-1
Unobstructed Flow Requirements.....	2-2
Installing the Flow Meter.....	2-3
Changing Display Orientation .....	2-3
Wiring Connections .....	2-5
Input Power Wiring.....	2-5
Output Signal Wiring.....	2-8
Alarm Output Wiring.....	2-11
Remote Sensor Probe Wiring.....	2-12
Range Selection Wiring .....	2-14

## Chapter 3 Operating Instructions

Flow Meter Start Up .....	3-1
Using the Smart Electronics Basic Features .....	3-3
Hazardous-Area Enclosure Optional LCD Display .....	3-3
LCD Display Programming Menu.....	3-4
Single-Digit LED Programming Menu.....	3-5
Entering Alarm Parameters.....	3-6
K-Factor Adjustment .....	3-7
User Full Scale Adjustment .....	3-9
Time Response Delay Adjustment.....	3-10
Totalizer Reset .....	3-11
Using the Smart Electronics Advanced Features.....	3-12
Voltage Zero Adjustment.....	3-12
Voltage Span Adjustment .....	3-12

Current Zero Adjustment .....	3-14
Current Span Adjustment.....	3-14
Instrument Validation .....	3-15
Electronics Validation Procedure .....	3-16
Sensor Validation Procedure.....	3-18

## Chapter 4 Troubleshooting and Repair

Troubleshooting the Flow Meter .....	4-1
Returning Equipment to the Factory.....	4-3

## Appendix A 780S Product Specifications

## Appendix B 760 Product Specifications

## Appendix C Warranty Policy

## List of Figures

1-1. Series 780S Flow Sensing Principle .....	1-3
2-1. Flow Meter Orientation.....	2-2
2-2. Wiring Access NEMA 4X Enclosures.....	2-4
2-3. Wiring Access Hazardous-Area Enclosures .....	2-4
2-4. AC Input Power Connections .....	2-5
2-5. Ferrite Clamp Installation .....	2-5
2-6. DC Input Power Connections (NEMA 4X) .....	2-6
2-7. DC Input Power Connections (Hazardous-Area) .....	2-6
2-8. DC Output Signal Connections (NEMA 4X) .....	2-7
2-9. DC Output Signal Connections (Hazardous-Area).....	2-7
2-10. Load Resistance Versus Input Voltage.....	2-8
2-11. Isolated 4-20 mA Loop (NEMA 4X).....	2-9
2-12. Non-isolated 4-20 mA Loop (NEMA 4X).....	2-9
2-13. Isolated 4-20 mA Loop (Hazardous-Area) .....	2-9
2-14. Non-isolated 4-20 mA Loop (Hazardous-Area) .....	2-9
2-15. Isolated Alarm Connections (NEMA 4X) .....	2-10
2-16. Non-Isolated Alarm Connections (NEMA 4X) .....	2-10
2-17. Isolated Alarm Connections (Hazardous-Area).....	2-11
2-18. Non-isolated Alarm Connections (Hazardous-Area)....	2-11
2-19. Remote Electronics to Sensor (NEMA 4X).....	2-12
2-20. J Box to Remote Enclosure (NEMA 4X) .....	2-12
2-21. Remote Electronics to Sensor (Hazardous-Area) .....	2-12
2-22. J Box to Remote Enclosure (Hazardous-Area).....	2-13
2-23. Range Selection Wiring (NEMA 4X).....	2-13
2-24. Range Selection Wiring (Hazardous-Area) .....	2-13

3-2. Magnetic Switch Operation .....3-2  
3-3. Electronics Validation Component Locations .....3-13  
3-4. Sensor Validation Component Locations .....3-15

### List of Tables

2-1. Pipe Length Requirements for Installation .....2-2  
3-1. Electronics Validation Results .....3-15  
3-2. Sensor Validation Results .....3-16

## Warnings and Cautions



**Warning!** Agency approval for hazardous location installations varies between flow meter models. Consult the flow meter nameplate for specific flow meter approvals before any hazardous location installation.

**Warning!** All wiring procedures must be performed with the power off.

**Warning!** To avoid potential electric shock, follow National Electric Code safety practices or your local code when wiring this unit to a power source and to peripheral devices. Failure to do so could result in injury or death. All AC power connections must be in accordance with published CE directives.

**Warning!** Do not power the flow meter with the sensor jumper wires disconnected. This could cause over-heating of the sensors and/or damage to the electronics.

**Warning!** Before attempting any flow meter repair, verify that the line is de-pressurized.

**Warning!** Always remove main power before disassembling any part of the mass flow meter.



**Caution!** Changing the length of cables or interchanging sensors or sensor wiring will affect the accuracy of the flow meter. You cannot add or subtract wire length without returning the meter to the factory for re-calibration.

**Caution!** When using toxic or corrosive gases, purge the line with inert gas for a minimum of four hours at full gas flow before installing the meter.

**Caution!** The AC wire insulation temperature rating must meet or exceed 71°C (158°F).

**Caution!** Before making adjustments to the Smart Electronics device, verify the flow meter is not actively monitoring or reporting to any master control system. Adjustments to the electronics will cause direct changes to flow control settings.

**Caution!** Printed circuit boards are sensitive to electrostatic discharge. To avoid damaging the board, follow these precautions to minimize the risk of damage:

- before handling the assembly, discharge your body by touching a grounded, metal object
- handle all cards by their edges unless otherwise required
- when possible, use grounded electrostatic discharge wrist straps when handling sensitive components

# Chapter 1 Introduction

## Series 780S FlatTrak™ Mass Flow Meters

Sierra's Series 780S FlatTrak Mass Flow Meter provides a reliable solution for monitoring gas mass flow rate. Low-flow sensitivity, fast response and outstanding rangeability have made this model the instrument of choice for many critical gas flow applications. The Series 780S meter solves the problems associated with monitoring flow in installations where long runs of straight pipe are not available. The instrument's built-in flow conditioner creates a uniform velocity profile by means of two stainless-steel perforated plates welded into the body between the sensor and the inlet connection. With flow conditioning, upstream piping requirements are reduced to less than three diameters after most common flow disturbances.

The flow meter's versatile microprocessor-based transmitter integrates the functions of flow-range adjustment, meter validation and diagnostics in a probe-mounted or remotely mounted housing. Mass flow rate and totalized flow, as well as other configuration variables are displayed on the meter's optional LCD display. The meter provides an optical/galvanic isolated flow output, two alarm outputs and one contact input for range or gas selection. The programmable transmitter is easily configured via RS-232 and Sierra's Smart Interface™ software or through three push buttons built into the device.

The Series 780S Mass Flow Meter's simple installation combines with an easy-to-use interface that provides quick set up, long term reliability and accurate mass flow measurement over a wide range of flows and conditions.

### ***Using This Manual***

This manual provides the information you need to install and operate the Series 780S Mass Flow Meter. The four chapters of this manual cover the following areas:

- Chapter 1 includes the introduction and product description
- Chapter 2 provides installation and wiring instructions
- Chapter 3 describes system operation and programming
- Chapter 4 covers troubleshooting and repair

The product specifications are found in Appendix A.

## Note and Safety Information

We use note, caution and warning statements throughout this book to draw your attention to important information.



### Warning!

This statement appears with information that is important to protect people and equipment from damage. Pay very close attention to all warnings that apply to your application.



### Caution!

This statement appears with information that is important for protecting your equipment and performance. Read and follow all cautions that apply to your application.



### Note

This statement appears with a short message to alert you to an important detail.

## Receipt of System Components

When receiving a Sierra mass flow meter, carefully check the outside packing carton for damage incurred in shipment. If the carton is damaged, notify the local carrier and submit a report to the factory. Remove the packing slip and check that all ordered components are present. Make sure any spare parts or accessories are not discarded with the packing material. Do not return any equipment to the factory without first contacting Sierra Customer Service.

## Technical Assistance

If you encounter a problem with your flow meter, review the configuration information for each step of the installation, operation and setup procedures. Verify that your settings and adjustments are consistent with factory recommendations. Refer to Chapter 4, Troubleshooting, for specific information and recommendations.

If the problem persists after following the troubleshooting procedures outlined in Chapter 4, contact Sierra Instruments by fax or by E-mail (see inside front cover). For urgent phone support you may call (800) 866-0200 or (831) 373-0200 between 8:00 a.m. and 5:00 p.m. PST. In Europe contact Sierra Instruments bv at +31 20 6145810. When contacting Technical Support, make sure to include this information:

- the flow range, serial number and Sierra order number (all marked on the meter nameplate)
- the software version (visible at start up)
- the problem you are encountering and any corrective action taken
- application information (gas, pressure, temperature and piping configuration)



## The Series 780S Flow Sensing Principle

Sierra's unique Steel-Trak™ sensor probe is responsible for the unsurpassed accuracy, ruggedness and reliability of Sierra industrial flow meters. The immersible Steel-Trak sensor consists of two sensing elements—a velocity sensor and a temperature sensor that automatically corrects for changes in gas temperature.

When power is applied to the flow meter, the transducer electronics heats the velocity sensor to a constant temperature differential above the gas temperature and measures the cooling effect of the gas flow. The electrical power required to maintain a constant temperature differential is directly proportional to the gas mass flow rate.

Both sensors are reference-grade platinum resistance temperature detectors (RTDs). The platinum RTD wire is wound on a rugged ceramic mandrel for strength and stability. Steel-Trak sensors are clad in a rugged, sealed 316 stainless steel encasement.

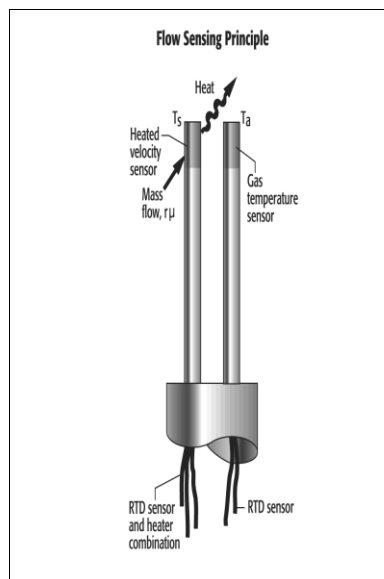

Figure 1-1. Series 780S Flow Sensing Principle

## Smart Electronics Features

### Instrument Validation

Two simple tests offer full “field-validation” of your Smart mass flow meter. The first test checks the system electronics, linearization and microprocessor functionality and is performed by injecting a known input value and confirming that the flow meter outputs the expected value. The second test verifies that the instrument’s primary sensing elements have not drifted or shifted from their original calibration and is accomplished by measuring the resistance of the velocity and temperature sensors and comparing the results to the NIST-traceable calibration data provided with the flow meter. Together, these tests confirm that your meter is working correctly and the calibration variables did not drift, shift or change values.

### Dual Range or Dual Gas Calibration (Optional)

Select one of two factory calibrated flow ranges using a simple external customer-supplied single contact closure.

### User Full Scale Flow Rate

Field-configure from 50% to 100% of the factory full scale setting (factory full scale is normally set to 125% of the user-specified maximum flow rate). This adjustment can be made for each flow range.

### Alarms

Program high and low or window alarm limits independently for each flow range. The solid state contacts are optically isolated.

### K-Factor Correction

Change the calibration correction factor to compensate for flow profile disturbances or specific application conditions. The K-factor is a multiplication factor applied to the linearized flow signal. You may set the K-factor individually for each flow range.

### Dual Output Signals

The flow meter offers two separate linear output signals proportional to flow, 0-5 VDC (0-10 VDC optional) and 4-20 mA. The 4-20 mA output can be field-configured as an active loop powered by the flow meter or an optically isolated passive loop requiring an external power supply.

**Totalizer**

With the optional LCD display, actual mass flow appears on line 1 and the totalized flow on line 2 both in the user-specified engineering units. The totalizer counts only the selected range and when ranges are switched, the value of the non-selected range is stored in memory. You may reset the totalizer using the membrane buttons or by using a hand-held magnet.

**Zero and Span Outputs**

Validate and adjust the settings to ensure output circuits are correct.

**Time Response Delay**

Select from a low response for faster tracking to a high response for a smoother output.

**Enclosure Options**

Flow meter electronics are available mounted directly to the flow body, or remotely mounted up to 200 feet away. The electronics housing may be used indoors or out, including wet environments.

Display options include a 2 x 12 character LCD display of mass flow rate including totalized mass, or a single-digit LED located on the device printed circuit board. Local operation and reconfiguration is accomplished using the three push buttons operated via finger touch. Smart electronics include nonvolatile memory that stores all configuration information. The memory allows the flow meter to function immediately upon power up, or after an interruption in power.

**Smart Interface™ Software**

Sierra's Smart Interface Windows™-based software is available for connecting your PC directly to the mass flow meter. An RS-232 serial cable along with floppy disks containing the program and system files are available from the factory. See the Smart Interface User Guide included with the software package for operating instructions. (Order code for this package is 780-SIP.)

## Chapter 2 Installation

### Installation Overview



Agency approval for hazardous location installations varies between flow meter models. Consult the flow meter nameplate for specific flow meter approvals before any hazardous location installation.

The FlatTrak™ 780S Series is available with ANSI or DIN flanges, ANSI Kynar flanges, NPT or butt-weld connections. For ease of installation, the meter is pre-assembled with the sensor probe installed in the flow body.

When selecting an installation site, make sure that:

1. Line pressure and temperature will not exceed the flow meter rating. Temperature should not vary more than 200°F (100°C) around the calibration temperature. Line pressure should not vary more than 50 psi (3.4 bar) around the calibrated pressure.
2. The location meets the required minimum number of pipe diameters upstream and downstream of the sensor head (see Table 2-1).
3. Safe and convenient access with adequate clearance. Also, verify the meter is located where the gas is clean and dry and the meter is calibrated for the gas to be measured.
4. When using a CSA, FM or EEx approved flow meter, verify that the cable entry into the instrument meets the specific standard required for that approval.
5. For remote installations, verify the supplied cable length is sufficient to connect the flow meter sensor to the remote electronics. (Do not extend or shorten the supplied cable between the probe and the electronics.)
6. **CAUTION:** Do not over tighten bolts on Kynar flow bodies. Do not over tighten NPT threaded fitting on Kynar flow bodies. Chlorine is a corrosive and poisonous gas. Sierra Instruments is not responsible for leakage, cracking or over pressurization of the flow body. The unit has been leak and Pressure tested under 345 PSI (23 Barg). Check the unit thoroughly for transport damage before installation

Also, before installation check your flow system for anomalies such as:

- leaks

- valves or restrictions in the flow path that could create disturbances in the flow profile that might cause unexpected flow rate indications
- heaters that might cause rapid excursions in the measured temperature

### *Unobstructed Flow Requirements*

Select an installation site that will minimize possible distortion in the flow profile. Valves, elbows, control valves and other piping components may cause flow disturbances. Check your specific piping condition against the examples shown below. To achieve accurate and repeatable performance, install the flow meter using the recommended number of straight run pipe diameters upstream of the sensor.

Piping Condition	Upstream <sup>(1)</sup> Requirements
Single 90° Elbow or T-piece	1 D
Same Plane	3 D
Different Plane	3 D
Reduction	3 D
Expansion	3 D
After Control Valve	5 D

(1) Number of diameters (D) of straight pipe required between upstream disturbance and the flow meter sensor.

*Table 2-1. Pipe Length Requirements for Installation*

#### **For Kynar Bodies:**

Minimum required straight piping before the flow meter.

Unlike the sierra 780S Series the 760S Series does not contain built-in flow conditions. Straight piping before the flow meter is therefore very important for proper operation. See table below.

Piping Condition	760
Single 90° elbow or T-piece	28D
Reduction (4:1)	14 D
Expansion (4:1)	30 D
After a control valve	32 D
Two 90° elbows (in same plane)	36 D
Two 90° elbows (different planes)	62D

(1) Number of diameters (D) of straight pipe required between upstream disturbance and the flow meter sensor.  
NOTE: 5D Required after flow meter

*Table 2-2. Pipe Length Requirements for Installation for Kynar Bodies*

## Installing the Flow Meter

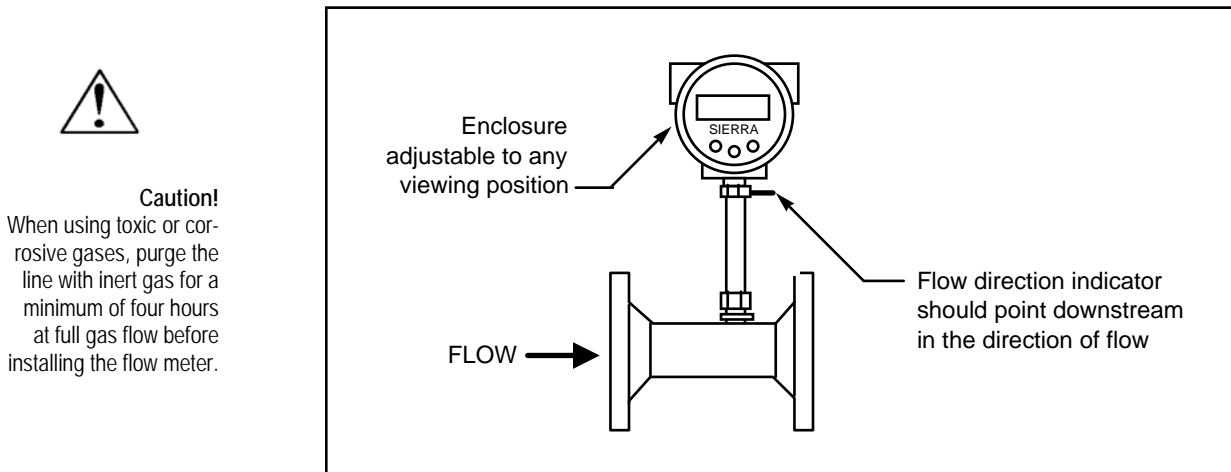



Figure 2-1. Flow Meter Orientation (Flange Connection Shown)

  
**Caution!**  
When using toxic or corrosive gases, purge the line with inert gas for a minimum of four hours at full gas flow before installing the flow meter.

When positioning the flow meter, refer to the flow direction indicator attached to the probe. For proper operation, install the meter with the flow direction indicator pointing downstream in the direction of flow. Installing the meter opposite this direction may result in inaccurate flow measurement.

To install the flow meter:

1. Turn off the flow of process gas. Verify that the line is not pressurized. Confirm that the installation site meets the minimum upstream pipe diameter requirements shown in Table 2-1.
2. Prepare the fluid connection fittings or flanges in the pipeline. (Fitting components should be blown clean with filtered gas before use.) Mount in a vertical position. For horizontal pipelines having a process gas temperature above 300° F (130°C), mount the flow meter at a 90-degree angle to avoid overheating the electronics enclosure.
3. Seat the flow meter level and square on the mating fluid connections with a gasket in place for each side for flange types. (Make sure both gaskets are smooth and even with no gasket material protruding into the flow profile; obstructions in the pipeline could cause inaccurate flow measurement.) Make sure that the flow direction indicator is pointing downstream in the direction of flow.

4. Secure the fluid connections as specified in the technical guidelines furnished by the fitting or flange manufacturer.
5. If needed, adjust the optional display to the desired orientation, as follows.

### ***Changing Display Orientation (Hazardous-Area Enclosures Only)***

Depending on installation requirements, you may need to change the position of the optional display. To rotate the display board:

1. Use a 1/16-inch hex key to loosen the set screw securing the larger end of the enclosure. Turn cover counterclockwise and remove.
2. Remove 4 screws and standoffs from the display. Release the latch securing the display ribbon cable connector from the display board.
3. Rotate the display board to the desired position. Re-connect the ribbon cable to the display board.
4. Replace the 4 screws and standoffs. Replace the enclosure cover. Tighten set screw.

**Warning!**

Failure to adhere to these guidelines may result in water damage that is not covered under Sierra's [Warranty Policy](#).

## Wiring Connections - Protection of Your Meter

For To protect your investment and be certain of a long reliable service life, we have compiled some guidelines (from experience) that will aid your installation team in properly protecting the electronics from the application environment. These instruments have been designed for and proven reliable in some of the most extreme process conditions in industry: Mining, Oil and Gas, Water, Wastewater etc. The key however is to follow best practices to insure a proper seal to protect the internal components of this precision instrument.

Water penetration can lead to a damaged flow meter. Sierra's "E" HALE ex-proof enclosures are rated to a NEMA4X, IP66 rating. This provides protection against, rain, sleet, snow and splashing water, but water can damage the sensor, electronics or wiring terminals if the meter is not properly installed and maintained.

To minimize the potential for water damage, Sierra Instruments recommends the following:

- Install conduit seals near the enclosures on all ports.
- Use a cable gland design that provides shielded cable termination and an environmental seal against dirt and water.
- Do not bend, kink, or otherwise distort the cable at the entry points to the cable glands.
- Route conduit or cable using a drip loop or drain as close as possible to the enclosure ports unless the cable slopes directly down.
- If the factory cable glands are replaced to install other adapter fittings, conduit fittings, cable glands, or any other modification to the cable entry points be sure to use a good quality thread sealant on all NPT threads as well as verifying they are all tightened and sealed appropriately so as not to leak.
- Be certain to use NPT threads when connecting to the housing. Some electrical fittings are not tapered but will fit in the NPT ports of the enclosure. Sufficient Teflon tape and pipe dope is recommended to insure a leak tight seal.
- If you are uncertain of the conditions the interior of the housing is subjected to over time, a small temporary data-logger can be placed in the housing to record temperature and humidity to establish a baseline. Corrective action can be made based on this data before instrument degradation



sets in. Contact Sierra Instruments for suggested sources of small dataloggers.

- Keep the enclosure lids sealed tight using the supplied o-rings.
- As part of the lid o-ring inspections look for any signs of condensation inside of the enclosure. If condensation or signs of condensation/corrosion are found be sure all fittings/seals are securely tightened as well as a desiccant bag can be used and replaced as needed. This can be particularly important if the temperature is cycled.

## Wiring Connections- General

For NEMA 4X enclosures, use TB2 for power and signal connections, TB1 is for sensor connections. (The terminal designations are labeled inside the enclosure cover.)



### Warning!

To avoid potential electric shock, follow National Electric Code safety practices or your local code when wiring this unit to a power source and to peripheral devices. Failure to do so could result in injury or death. All AC power connections must be in accordance with published CE directives.

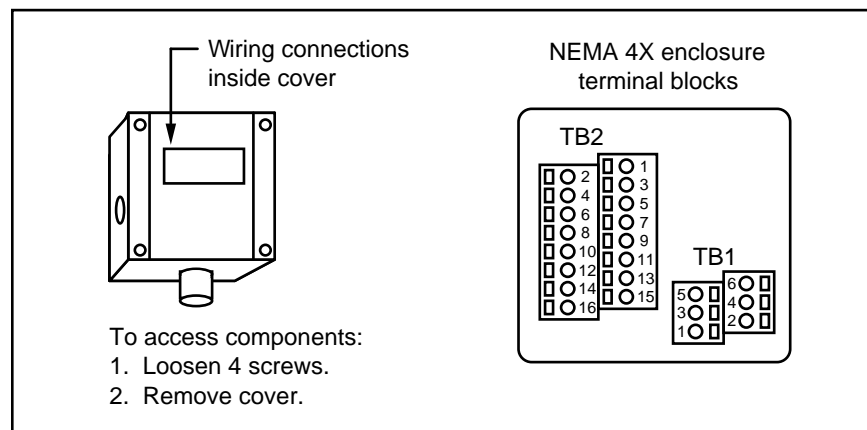

Figure 2-2. Wiring Access NEMA 4X Enclosures

For Hazardous-Area enclosures, use the terminal blocks located inside the smaller end of the flow meter enclosure for all wiring connections. (The terminal designations are labeled inside the enclosure cover.) Make sure to observe all CE compliance requirements for AC wiring connections given on the next page.

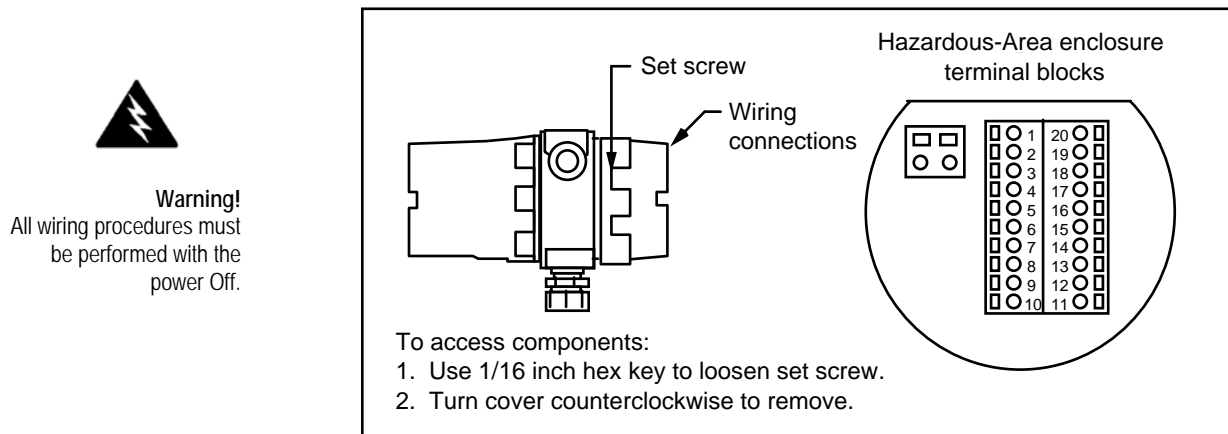

Figure 2-3. Wiring Access Hazardous-Area Enclosures

## Input Power Wiring

### AC Power Wiring

The AC power wire size must be 26 to 16 AWG with the wire stripped 1/4 inch (6 mm). Connect 100 to 240 VAC (300 mA load, maximum) to the Neutral and Line terminals on the small, two-position terminal block. Connect the ground wire to the safety ground lug. Torque all connections to 4.43 to 5.31 in-lbs (0.5 to 0.6 Nm).

For all installations not using solid metal conduit, the ferrite clamp must be installed just above the input power wire entry into the enclosure (Figure 2-5). All EEx installations must use an approved EEx fitting at both cable entries into the enclosure. If conduit seals are used, they must be installed with 18 inches of the enclosure.

The Hazardous-Area enclosure has two separate conduit entries to maintain separation between AC input power and output signal wiring. To eliminate the possibility of noise interference use a separate cable entry for the AC power and signal lines.



**Caution!**

The AC wire insulation temperature rating must meet or exceed 71°C (158°F).

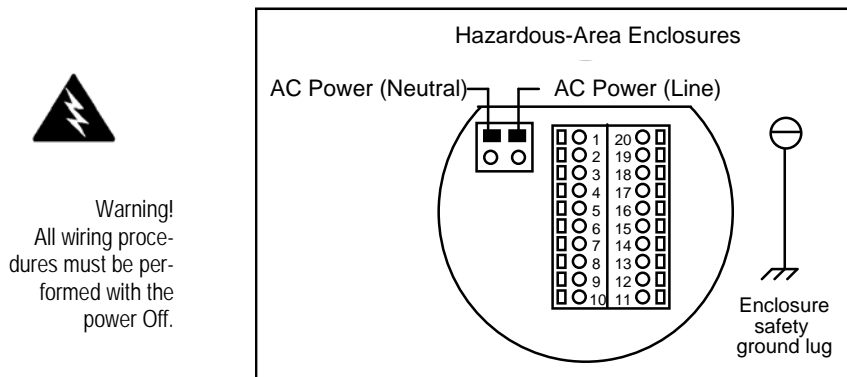

Figure 2-4. AC Input Power Connections

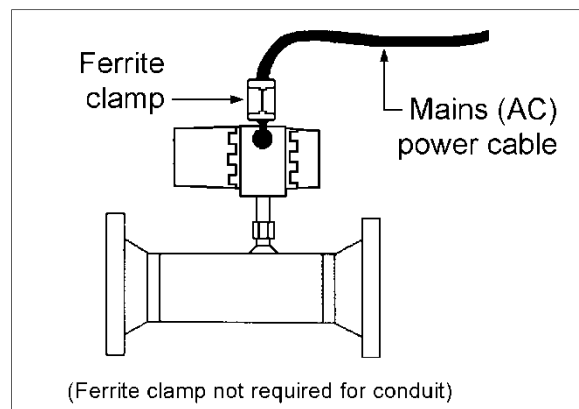

Figure 2-5. Ferrite Clamp Installation

### DC Power Wiring

The DC power wire size must be 26 to 16 AWG with the wire stripped 1/4 inch (6 mm). Connect 18 to 30 VDC (625 mA load, maximum) to the terminals marked PWR+ and PWR– on the terminal block. Torque all connections to 4.43 to 5.31 in-lbs (0.5 to 0.6 Nm).

All EEx installations must use an approved EEx fitting at both cable entries into the enclosure. If conduit seals are used, they must be installed within 18 inches of the enclosure.

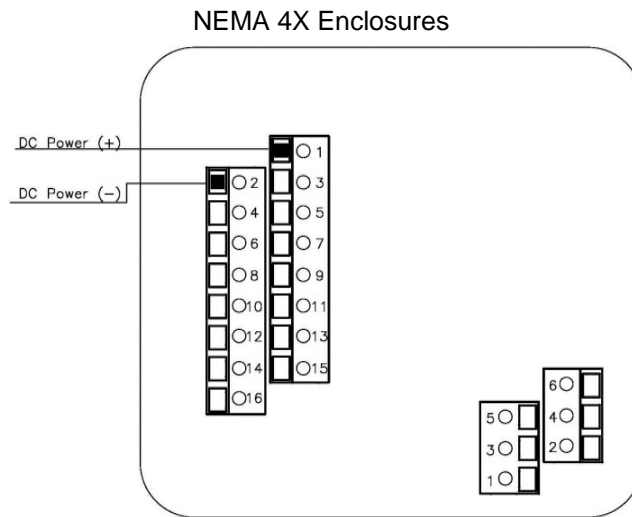

Figure 2-6. DC Input Power Connections

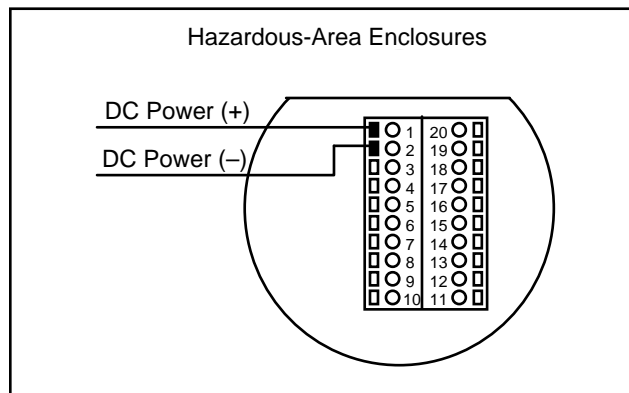

Figure 2-7. DC Input Power Connections

## Output Signal Wiring

Output signal cable should be completely screened with a 100% shield. You must use metal cable glands that provide cable screen clamping. The cable screen should be connected to the gland and shielded at both ends over 360 degrees. The shield should be terminated to an earth ground.

Flow meters are equipped with either a calibrated 0-5 VDC (0-10 VDC optional) or a calibrated 4-20 mA output signal. This linear output signal represents 0-100% of the flow meter's user full scale.

### DC Output Wiring

The 0-5 VDC (0-10 VDC optional) signal can drive a minimum load of 1000 Ohms. Note: the optional 0-10 VDC output signal is not available for power sources below 15 VDC.

For 0-5 VDC or 0-10 VDC connections, connect to the terminals marked Vout (+) and Vout (–) as shown below.

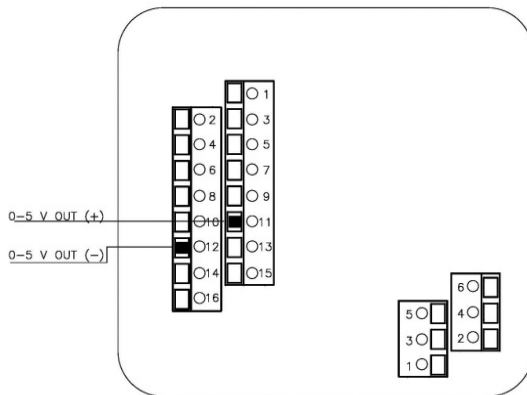

Figure 2-8. DC Output Signal Connections

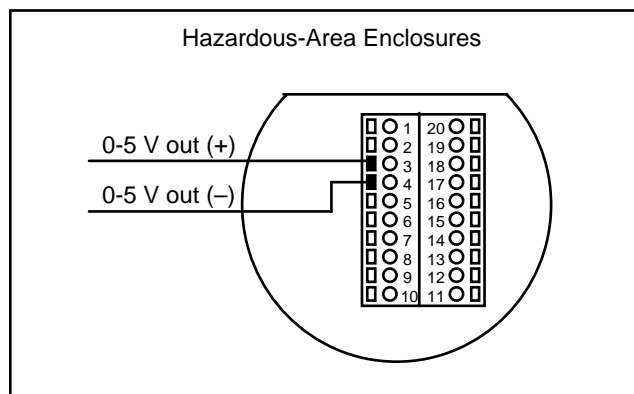

Figure 2-9. DC Output Signal Connections

### 4-20 mA Output Wiring

The 4-20 mA current loop output can be self-powered (non-isolated) or externally powered (isolated). To use the 4-20 mA isolated output, an external 12 to 36 VDC power supply is required. The maximum loop resistance (load) for both types of current loop outputs are dependent upon the supply voltage and are given in Figure 2-10.

$R_{load}$  is the total resistance in the loop, including the wiring resistance. To calculate  $R_{max}$ , the maximum  $R_{load}$  for the loop, use the maximum loop current, 20 mA. The voltage drop in the loop due to resistance is 20 mA times  $R_{load}$  and this drop is subtracted from the input voltage. Thus:

$$R_{max} \text{ the maximum load resistance} = 50 * (V_{supply} - 7.5V)$$

To use an external power supply for an isolated 4-20 mA output, connect as shown in Figure 2-11 or Figure 2-13. For an internally powered, non-isolated 4-20 mA output, connect as shown in Figure 2-12 or Figure 2-14.

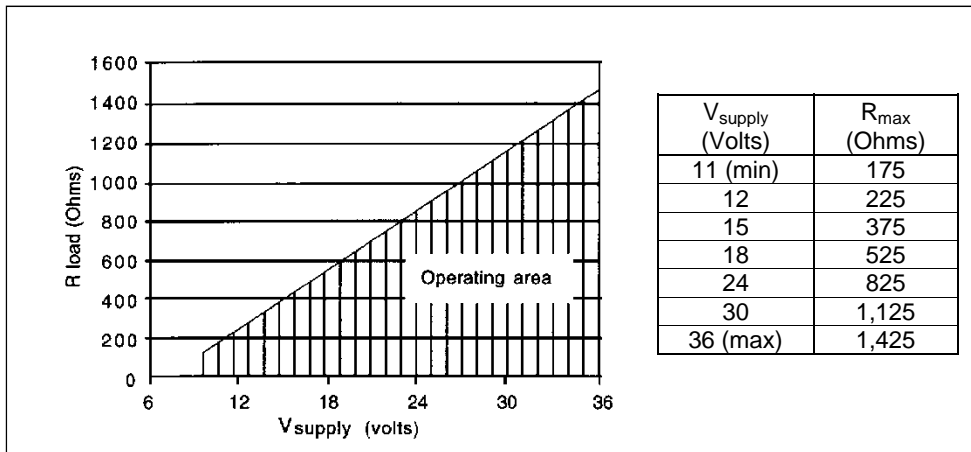

Figure 2-10. Load Resistance Versus Input Voltage

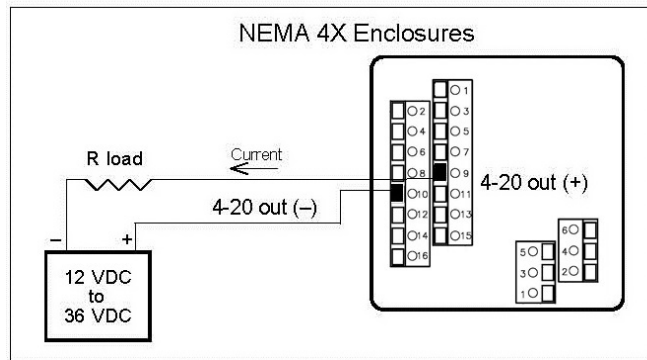

Figure 2-11. Isolated 4-20 mA Current Loop Connections

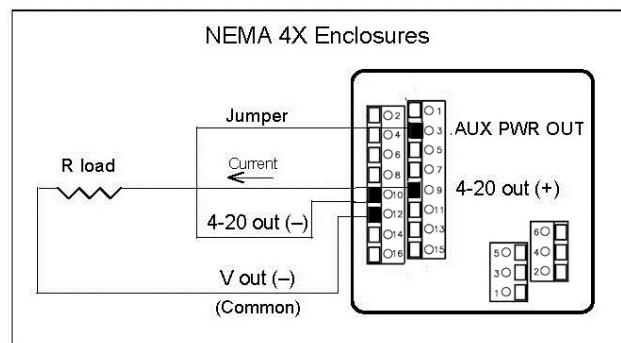

Figure 2-12. Non-Isolated 4-20 mA Current Loop Connections

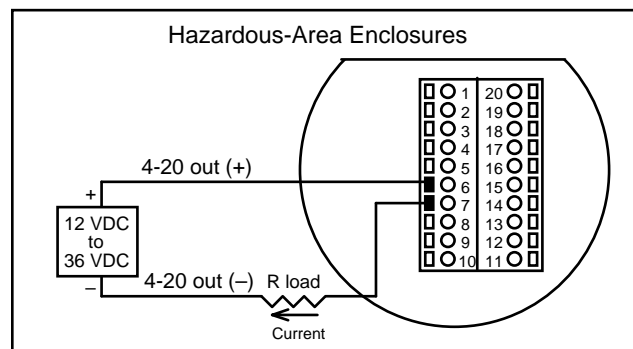

Figure 2-13. Isolated 4-20 mA Current Loop Connections

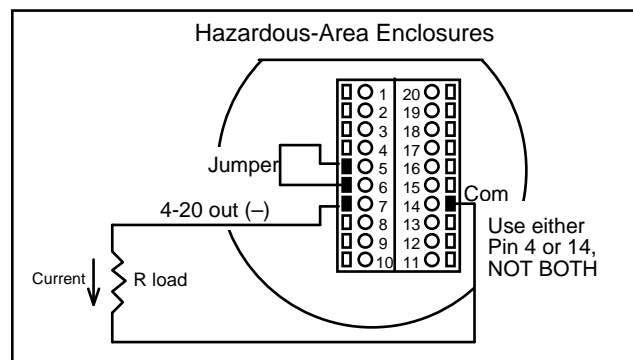

Figure 2-14. Non-Isolated 4-20 mA Current Loop Connections

### Alarm Output Wiring

Two alarm outputs (Low Alarm and High Alarm) are included on the flow meter terminal block. The alarm outputs use optical relays that are normally-open single-pole relays with one common connection.

There are two connection options for alarm outputs—the first with a separate power supply (isolated) and the second using the flow meter power supply (non-isolated). Use the first option with a separate power supply if a specific voltage is needed for the alarm output. Use the second (non-isolated) configuration if the voltage at the flow meter's power supply is an acceptable driver voltage for the load connected. (Take into account that the current used by your alarm loads have to come from the flow meter's power supply.) In either case, the voltage of the alarm output is the same as the voltage supplied to the circuit.

To use an external power supply for an isolated alarm output, connect as shown in Figure 2-15 or Figure 2-17. To use the internally powered, non-isolated alarm output connect as shown in Figure 2-16 or Figure 2-18. For a window alarm connect both outputs together.

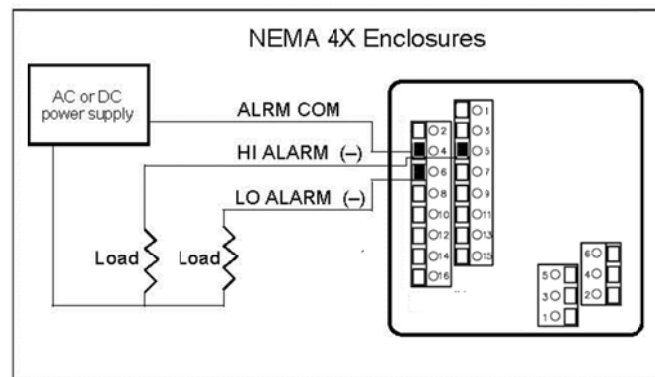

Figure 2-15. Isolated Alarm Output Connections

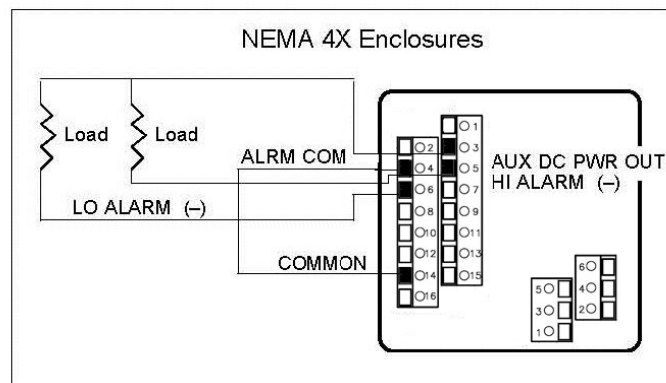

Figure 2-16. Non-Isolated Alarm Connections



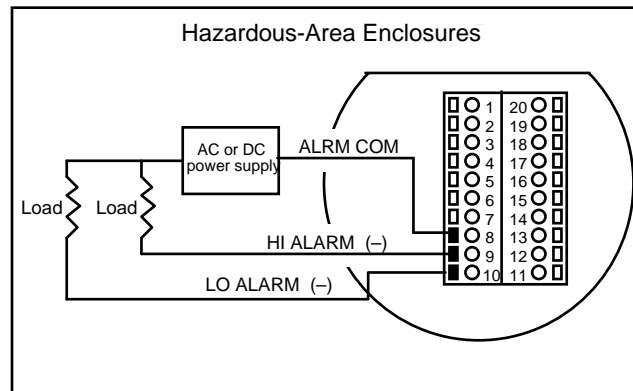

Figure 2-17. Isolated Alarm Output Connections

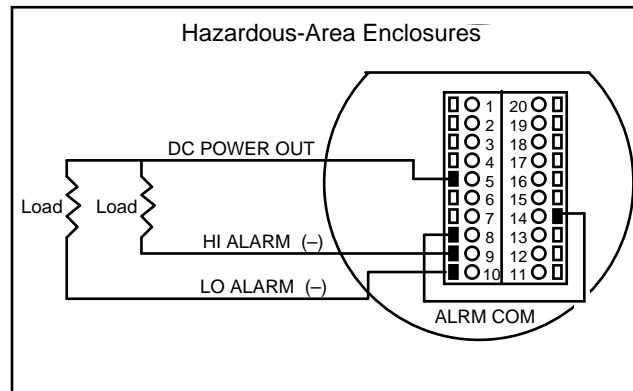

Figure 2-18. Non-Isolated Alarm Connections



### Remote Sensor Probe Wiring

#### Caution!

Changing the length of cables or interchanging sensors or sensor wiring will affect the accuracy of the flow meter. You cannot add or subtract wire length without returning the meter to the factory for recalibration.

When connecting the sensor probe to a remotely mounted flow meter enclosure, use only factory supplied cables. The electronics, sensors and interconnecting cables supplied by Sierra Instruments are calibrated as a complete precision mass flow circuit.

To connect the sensor probe to a remotely mounted electronics enclosure, see Figure 2-19 or Figure 2-21. To make wiring connections from a sensor probe junction box to a remotely mounted enclosure, see Figure 2-20 or Figure 2-22.

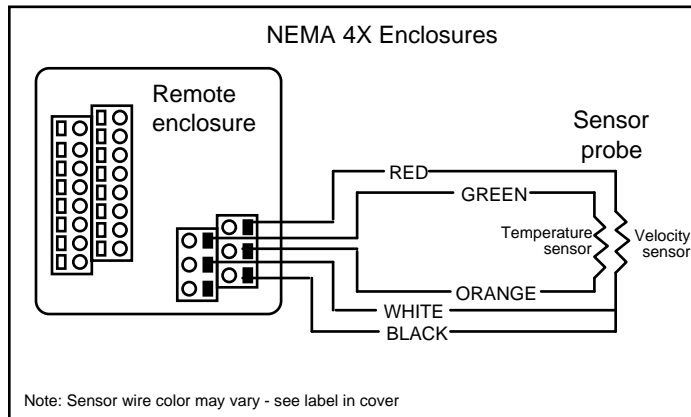

Figure 2-19. Remote Electronics Enclosure to Sensor Connections

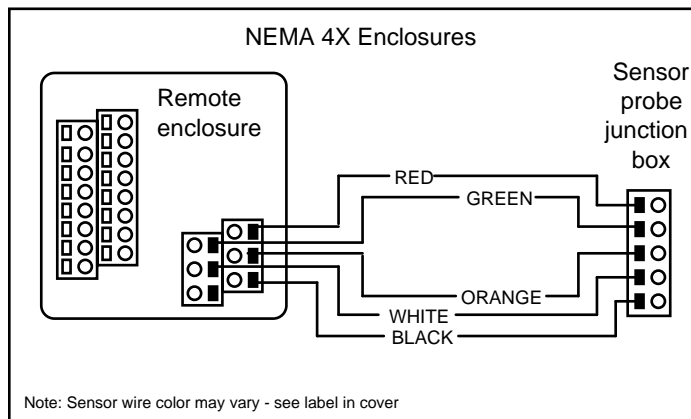

Figure 2-20. Sensor Junction Box to Remote Enclosure Connections

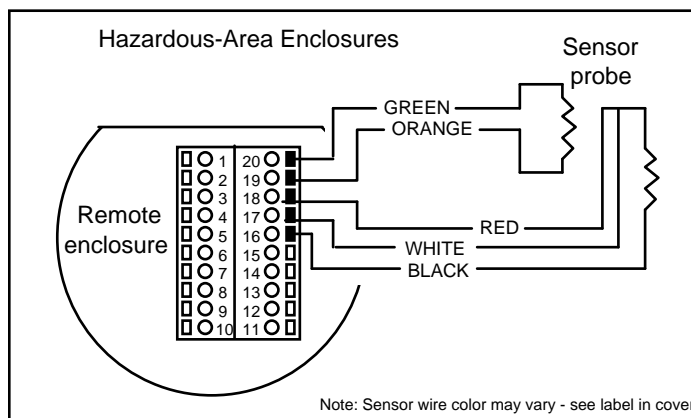

Figure 2-21. Remote Electronics to Sensor Connections

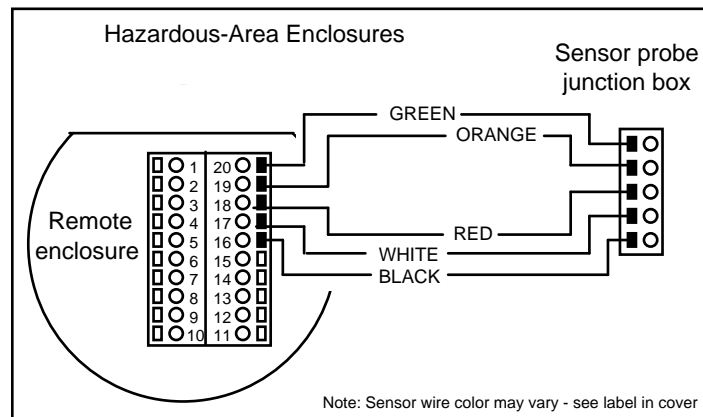

Figure 2-22. Sensor Junction Box to Remote Enclosure Connections

### Range Selection Wiring

To access range selection, connect two wires on the terminal strip as shown below. When the switch is closed the device changes to Range 2. Opening the switch returns the device to Range 1.

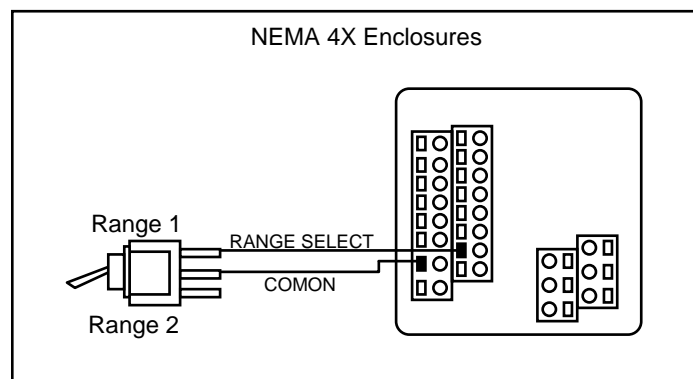

Figure 2-23. Range Selection Wiring

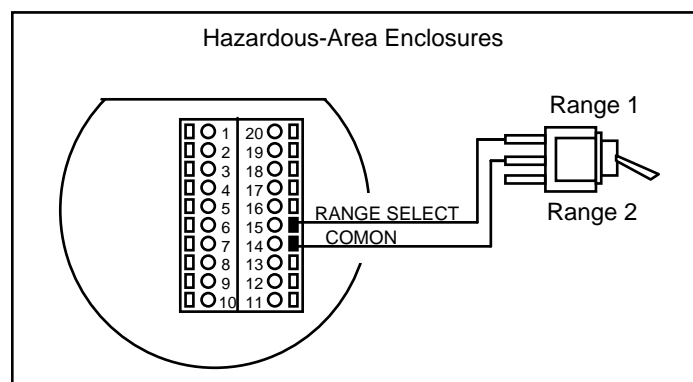

Figure 2-24. Range Selection Wiring

## Chapter 3 Operation

This chapter covers flow meter operation, programming and instrument validation procedures. All instructions include directions for using either the optional LCD display or the internal Smart electronics device for programming. If your meter is not equipped with the optional display, you will need a good quality digital voltmeter or multimeter for programming and validation procedures.

### Flow Meter Start Up

When applying power to a flow meter equipped with the optional LCD display you will see the product name, the software version, unit serial number, the range number, the user full scale (UFS), the current flow rate and the totalized flow. Any active alarm will flash on the screen every few seconds.

When applying power to a flow meter without the display, the Smart electronics on-board single-digit LED flashes the revision number of the software in a series of 3 digits followed by the range number. The range number continues to flash every three seconds thereafter.

### Record Factory-Set Parameters

You may view parameters using the optional LCD front panel display or by selecting functions on the single-digit LED and viewing the meter's 0-5 VDC output with a digital voltmeter (DVM).

For meters with the LCD display, use a hand-held magnet or the device buttons to select the FUNCTION key. When FUNCTION is selected, the display prompts for a password. Select FUNCTION again to skip the password to view and record the factory settings. To make changes, at the password prompt use the UP arrow until the number 11 is displayed. Select FUNCTION again to continue.

For flow meters without the display, remove the enclosure cover to access the Smart electronics device. Connect the DVM as described on the following pages and record the factory-set parameters.

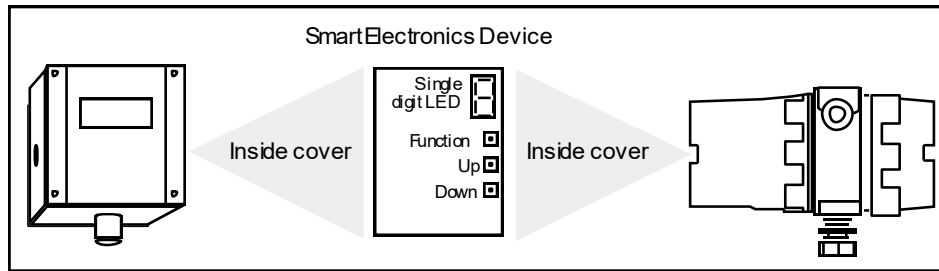

Figure 3-1. Smart Electronics Device Locations

## Using the Smart Electronics Basic Features



### Caution!

Before making any adjustment to the Smart electronics device, verify the flow meter is not actively monitoring or reporting to any master control system. Any adjustment to the electronics will cause direct changes to flow control settings.

This section covers the basic features of the Smart electronics and includes instructions on:

- entering alarm parameters
- changing the user full scale
- adjusting the K-factor
- adjusting the time response speed
- resetting the totalizer

To access the meter's advanced features of zero and span, turn to page 3-11. Instrument validation procedures begin on page 3-13.

Note: when programming the instrument, after 12 seconds of non-activity the meter returns to the Run Mode with any new settings immediately in effect. For units without a display, if the unit "times-out" press the FUNCTION button *only* to resume adjustments.

### Hazardous-Area Enclosure Optional LCD Display

For units with the optional display, you may program the meter without opening the enclosure using the magnetic switches to enter the desired system settings.

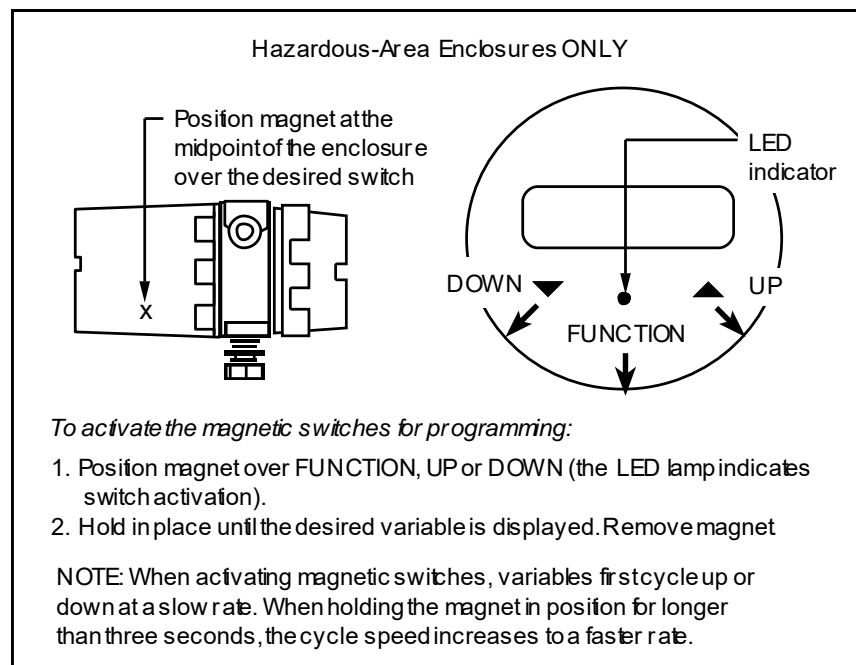
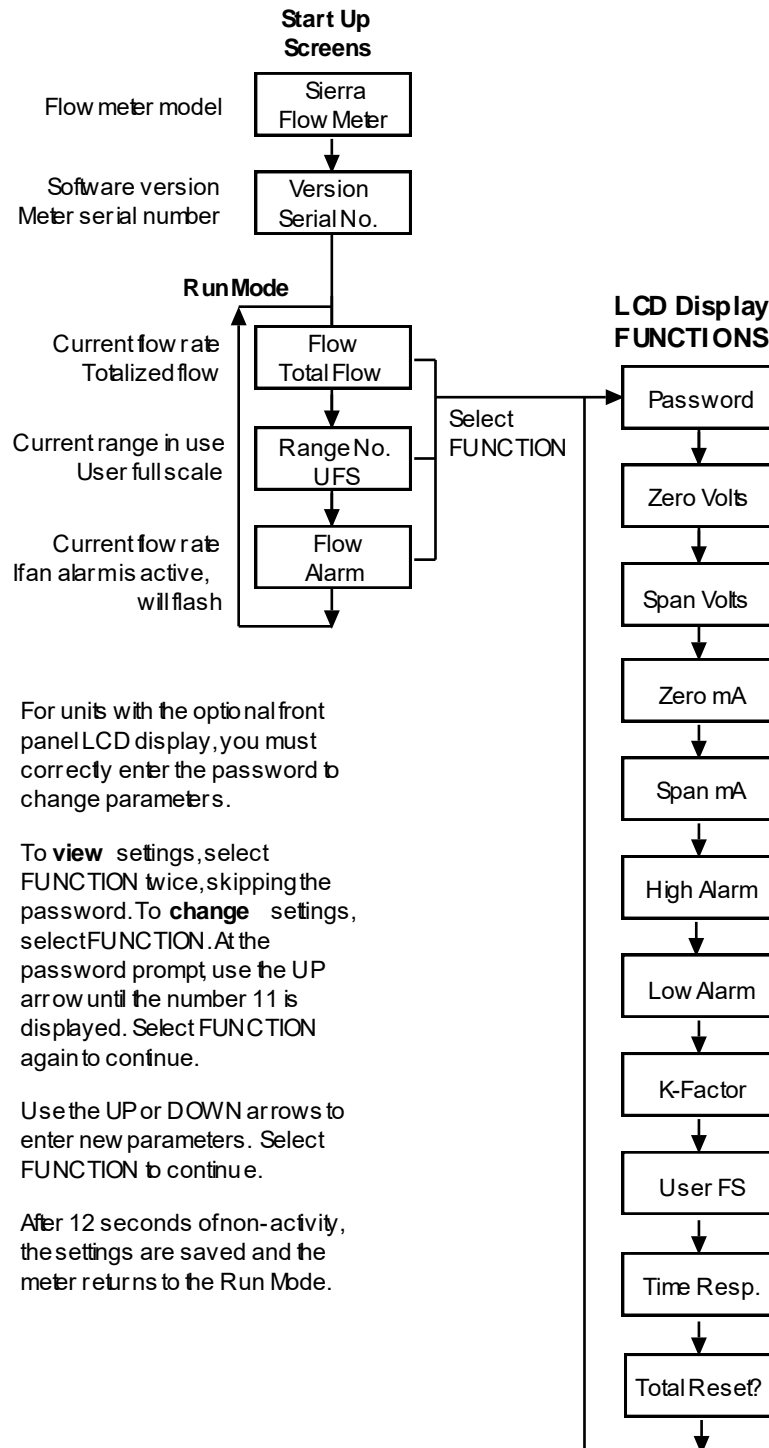

Figure 3-2. Magnetic Switch Operation

## LCD Display Programming Menu



For units with the optional front panel LCD display, you must correctly enter the password to change parameters.

To **view** settings, select FUNCTION twice, skipping the password. To **change** settings, select FUNCTION. At the password prompt, use the UP arrow until the number 11 is displayed. Select FUNCTION again to continue.

Use the UP or DOWN arrows to enter new parameters. Select FUNCTION to continue.

After 12 seconds of non-activity, the settings are saved and the meter returns to the Run Mode.

### Single-Digit LED Programming Menu

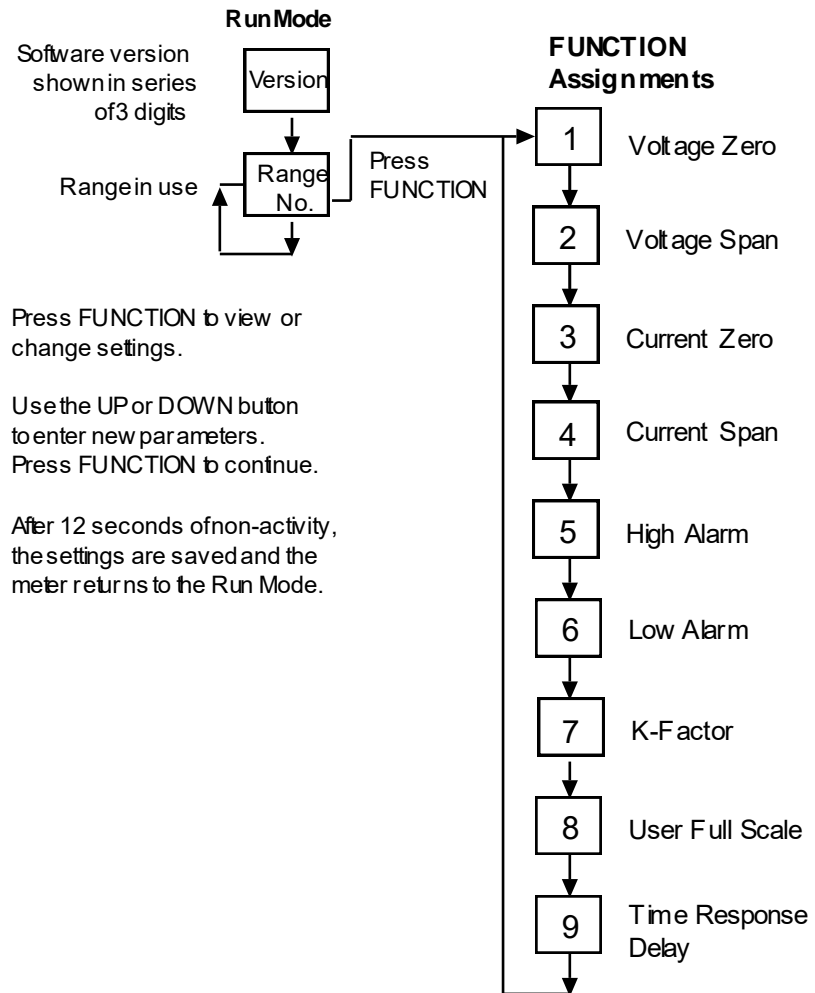



## Entering Alarm Parameters



### Caution!

The flow meter must not be reporting or measuring gas flow during adjustments.

Use the High Alarm and Low Alarm function to set or adjust alarm trip points. The alarms have a minimum hysteresis of 3% to avoid "chattering." When setting a window alarm, the alarm setpoints must be at least twice the hysteresis value apart. We suggest at least a 10% separation between window alarm setpoints. If you choose not to use the high alarm for a specific alarm function, Sierra recommends that you set the high alarm at 100% of the user full scale setting which creates an "over-range" indicator. Your flow meter will continue to indicate flow and generate a signal if the flow is over the maximum range, but will not operate within the specified accuracy.

### Entering Alarms using the LCD Display

Enter alarms setpoints directly in engineering units.

1. Select the desired range. Select FUNCTION, enter the password. Select FUNCTION again until *High Alarm* or *Low Alarm* appears on the display.
2. Use UP or DOWN to enter the high or low alarm setpoint value in engineering units.
3. Select FUNCTION to advance to the next option, or after 12 seconds of non-activity the meter returns to the Run Mode and the new parameters are in effect.

### Entering Alarms using the Single-Digit LED

When using a DVM to set alarms, the setpoint is a percentage of the flow meter's user full scale.

$$\text{VOLTS} = (\text{ALARM PERCENT} \times 5.0)$$

If you want to alarm at 25% of user full scale, used in Step 3 below, press the UP or DOWN button until 1.25 VDC is present on the DVM. If you want to alarm at 75% of user full scale, press the UP or DOWN button until 3.75 VDC is present on the DVM.

1. Set the DVM to voltage mode and connect between Vout+ and Vout- on the flow meter terminal block.
2. Select the desired range. Press the FUNCTION button until a solid "5" (high alarm) or solid "6" (low alarm) appears on the LED.

3. Adjust the UP or DOWN button until the DVM indicates the desired setpoint voltage as described above.
4. Press FUNCTION again to advance to the next option, or after 12 seconds of non-activity the meter returns to the Run Mode and the new alarm parameters are in effect.

### **K-Factor Adjustment**

Entering a K-factor adjusts the meter's output signal without affecting the factory calibration curve. Use the K-factor calibration offset for *additional* flow profile compensation (the factory includes an initial flow profile correction in the calibration curve of the unit).



#### **Caution!**

The flow meter must not be reporting or measuring gas flow during adjustments.

#### **Entering a K-factor using the LCD Display**

A K-factor value of 1.000 means the output value is not affected and is the factory default setting. You may enter any number from 0.500 to 5.000.

1. Select the desired range. Select FUNCTION, enter the password. Select FUNCTION again until *K-factor* appears on the display.
2. Use UP or DOWN to enter the desired K-factor value in engineering units.
3. Select FUNCTION to advance to the next option, or after 12 seconds of non-activity the meter returns to the Run Mode and the new K-factor is in effect.

#### **Entering K-factor using the Single-Digit LED**

A K-factor value of 1.000 VDC means the output value is not affected and is the factory default setting. You may enter any value from 0.500 to 5.000 VDC in Step 3 below. If the device indicated output is 3.0 VDC and you know it should be 3.8 VDC then you could “force” the output to the desired 3.8 VDC by adjusting the K-factor to indicate 1.27 VDC ( $1.27 = 3.8/3.0$ ). Use this formula to determine the desired K-factor voltage:

$$\text{VOLTS} = \text{DESIRED} / \text{INDICATED}$$

1. Set the DVM to voltage mode and connect between Vout+ and Vout– on the flow meter terminal block.

2. Select the desired range. Press the FUNCTION button until a solid “7” appears on the LED.
3. Adjust the UP or DOWN button until the DVM indicates the desired K-factor value as described above.
4. Press FUNCTION to advance to the next option, or after 12 seconds of non-activity the meter returns to the Run Mode and the new K-factor is in effect.

**Caution!**

The flow meter must not be reporting or measuring gas flow during adjustments.

## User Full Scale Adjustment

The user full scale (UFS) feature adjusts the flow meter output range anywhere within 50% to 100% of the factory full scale (FFS). This feature allows you to re-range the voltage or current output of the meter to accommodate different flow rates. Note: when entering a new user full scale setting for Range 2, it cannot be less than 10% of the Range 1 user full scale.

### Changing the User Full Scale using the LCD Display

The factory full scale is shown on the flow meter label. If you want a UFS equal to the FFS, adjust the display to match the FFS. If you want to use 50% of FFS, adjust the display to read 50% of the FFS.

1. Select the desired range. Select FUNCTION, enter the password. Select FUNCTION again until *User Full Scale* appears on the display.
2. Use UP or DOWN to enter the desired UFS value in engineering units.
3. Select FUNCTION to advance to the next option, or after 12 seconds of non-activity the meter returns to the Run Mode and the new UFS is in effect.

### Changing the User Full Scale using the Single-Digit LED

If the FFS is set to 11,000 sfpm and UFS is set to output 5.0 VDC, or 100%, the flow meter will indicate 5.0 VDC when 11,000 sfpm is present on the probe. If you want 6,000 sfpm for UFS, used in Step 3 below, adjust the UFS to 6000/11000 or 54.55% of factory full scale. Adjust the voltage to 2.73 VDC ( $2.73 = 5 \times .5455$ ). Use this formula to determine the desired UFS voltage:

$$\text{VOLTS} = 5 \times \text{User Full Scale} / \text{Factory Full Scale}$$

1. Set the DVM to voltage mode and connect between Vout+ and Vout- on the flow meter terminal block.
2. Select the desired range. Press the FUNCTION button until a solid “8” appears on the LED.
3. Adjust the UP or DOWN button until the DVM indicates the desired user full scale as described above.

4. Press FUNCTION to advance to the next option, or after 12 seconds of non-activity the meter returns to the Run Mode and the new UFS is in effect.

### ***Time Response Delay Adjustment***

#### **Changing the Time Response Delay using the LCD Display**

1. Select FUNCTION, enter the password. Select FUNCTION again until *Time Response* appears on the display.
2. Use UP or DOWN to adjust the time response delay from 0.10 to 7.2 seconds.
3. Select FUNCTION again to advance to the next option, or after 12 seconds of non-activity the meter returns to the Run Mode and the new time response setting is in effect.

#### **Changing the Time Response Delay using the Single-Digit LED**

1. Set the DVM to voltage mode and connect between Vout+ and Vout– on the flow meter terminal block. Select the desired range. Press the FUNCTION button until a solid “9” appears on the LED.
2. Adjust the UP or DOWN button until the DVM indicates the desired voltage (as shown in the following table).

Volts Indicated on DVM	Time Response (Seconds)	Volts Indicated on DVM	Time Response (Seconds)	Volts Indicated on DVM	Time Response (Seconds)	Volts Indicated on DVM	Time Response (Seconds)
0.5	0.1	1.0	0.3	1.5	0.5	2.0	0.7
2.5	1.2	3.0	1.8	3.5	2.4	4.0	3.6
4.5	4.8	5.0	7.2				

3. Press FUNCTION to advance to the next option, or after 12 seconds of non-activity the meter returns to the Run Mode and the new time response delay setting is in effect.

## Totalizer Reset

If your device is equipped with the optional LCD display, reset the totalizer using the magnetic switches or device buttons. If you are unable to open the flow meter enclosure, use a magnet to reset the totalizer as shown below.

### Reset the Totalizer using the LCD Display

1. Select the desired range. Select FUNCTION, enter the password. Select FUNCTION again until *Total Reset?* appears on the display.
2. Select the UP button and then the DOWN button until the display reads “Resetting Totalizer.”

### Reset the Totalizer without Opening the Enclosure

1. Position a magnet above the enclosure until the display reads “Resetting Totalizer.”

For Hazardous-Area enclosures only: To disable the magnetic reset function of the totalizer, remove jumper (J2) from the PCB at the location shown below. (You may not disable the magnetic reset switch on NEMA 4X enclosures.)

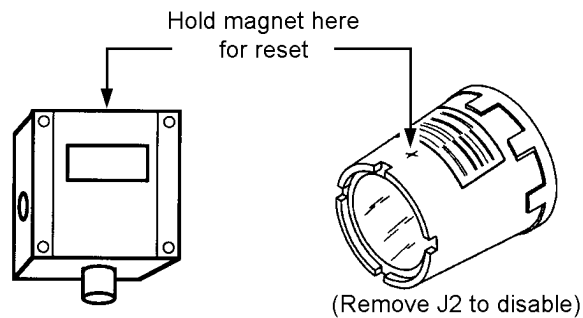

**Caution!**

Adjusting zero or span will affect meter calibration.

## Using the Smart Electronics Advanced Features

Zero and span (Function 1 through 4) can be used to validate system operation and calibrate the digital to analog signals on the Smart electronics device. Additionally, these functions can compensate for resistance in long signal cables connected to your data collection or indicating system.

You must use a certified digital voltmeter to adjust zero and span as the voltmeter acts as a standard. We recommend recording the current values as shown on the LCD display or DVM before making any changes to the zero and span settings. Note: when adjusting zero the voltage signal will be driven to 0 VDC and when adjusting span the voltage signal will be driven to 5 VDC (or 10 VDC).

### Voltage Zero Adjustment

If needed, use Zero Volts (Function 1) to adjust the 0-5 VDC output to 0.0 VDC, or optional 0-10 VDC to 0.0 VDC.

1. Set the DVM to voltage mode and connect between Vout+ and Vout-.
2. Select FUNCTION, enter the password (if so equipped). Select FUNCTION again until *Zero Volts* appears on the LCD display or a solid “1” appears on the LED. Adjust UP or DOWN until the DVM indicates between 0 and .01 VDC (no less than 0.005, the Smart electronics device cannot drive negative values).
3. After 12 seconds of non-activity, the meter returns to the Run Mode and the new parameter is in effect.

### Voltage Span Adjustment

If needed, use Span Volts (Function 2) to adjust the 0-5 VDC output to 5.0 VDC, or optional 0-10 VDC to 10 VDC.

1. Set the DVM to voltage mode and connect between Vout+ and Vout-.
2. Select FUNCTION, enter the password (if so equipped). Select FUNCTION again until *Span Volts* appears on the LCD display or a solid “2” appears on the LED. Adjust UP or DOWN until the DVM, indicates between 4.99 and 5.01 VDC. (For 0-10 VDC devices, the target value is 9.99 to 10.01.)

3. After 12 seconds of non-activity, the meter returns to the Run Mode and the new parameter is in effect.



Note: when adjusting zero the current signal will be driven to 4 mA and when adjusting span the current signal will be driven to 20 mA. We recommend recording the current values before making any changes to the current zero or span settings.

### Current Zero Adjustment



**Caution!**  
Adjusting zero or span will  
affect meter calibration.

If needed, use Zero mA (Function 3) to adjust the 4-20 mA output to 4.0 mA.

1. Disconnect the 4-20 mA (+) loop wire. Set the DVM to current mode and connect the positive lead to the wire you just disconnected. Connect the negative lead to the 4-20 mA (-) on the flow meter terminal block.
2. Select FUNCTION, enter the password (if so equipped). Select FUNCTION again until *Zero mA* appears on the LCD display or a solid “3” appears on the LED. Adjust UP or DOWN until the DVM indicates between 3.95 and 4.05 mA. Set DVM back to voltage mode when adjustment is complete.
3. After 12 seconds of non-activity, the meter returns to the Run Mode and the new parameter is in effect.

### Current Span Adjustment

If needed, use Span mA (Function 4) to adjust the 4-20 mA output to 20.0 mA.

1. Disconnect the 4-20 mA (+) loop wire. Set the DVM to current mode and connect the positive lead to the wire you just disconnected. Connect the negative lead to 4-20 (-) on the flow meter terminal block.
2. Select FUNCTION, enter the password (if so equipped). Select FUNCTION again until *Span mA* appears on the LCD display or a solid “4” appears on the LED. Adjust UP or DOWN 2 until the DVM indicates between 19.95 and 20.05 mA. Set DVM back to voltage mode when adjustment is complete.
3. After 12 seconds of non-activity, the meter returns to the Run Mode and the new parameter is in effect.

## Instrument Validation

System electronics are verified by injecting a known input value and confirming that the flow meter outputs the expected value. This test confirms that the microprocessor, analog to digital and digital to analog converters, the linearizer and the display are working properly. Sensor validation is accomplished by measuring the resistance of the velocity and temperature sensors and comparing the results to the NIST-traceable calibration data provided with the flow meter. These tests confirm that your meter is working correctly and the calibration variables did not drift, shift or change values.

To perform the instrument validation procedures you will need the following equipment:

- certified digital multimeter with minimum 4 character resolution, accuracy of at least  $\pm 0.1\%$  of range
- Calibration Certificate supplied with the flow meter
- small pot adjusting tool (screwdriver)

Before beginning the validation procedures, review Figure 3-3 and Figure 3-4 to familiarize yourself with the component locations.

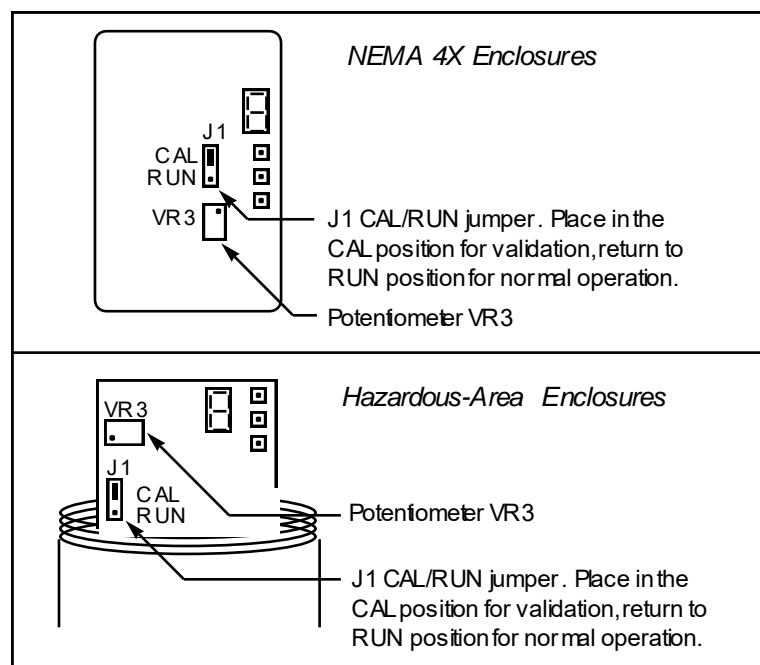

Figure 3-3. Electronics Validation Component Locations

### Electronics Validation Procedure

**Caution!**

Before beginning this procedure, make sure the flow meter is not actively monitoring or reporting to any master control system. Any adjustment to the electronics will cause direct changes to flow control settings.

1. Verify the flow meter is off line from any remote communications. Make sure the meter's user full scale setting is the same as the factory full scale setting. If not, adjust the user full scale value as needed.
2. Locate the Calibration Certificate supplied with the flow meter. Record in Table 3-1 the five bridge voltage values, the output (VDC or mA) values and the indicated flow values.
3. Remove power from the flow meter. Remove the cover(s) of the flow meter enclosure to access the wiring terminal block and the Smart electronics device.
4. Set the multimeter to the 20 volt range. Connect to BV(+) and BV(-) terminals on the flow meter terminal block.
5. Move the J1 Cal/Run jumper on the Smart electronics device to the CAL position. Locate potentiometer VR3 on the Smart electronics device. Turn on power to the flow meter.
6. Adjust potentiometer VR3 until the multimeter matches the first bridge voltage point (the value must be  $\pm 0.002$  VDC of the bridge voltage point).
7. Record the resulting flow shown on the optional LCD display in Table 3-1. If not using a display or if you prefer to validate one of the analog output signals, move the multimeter + connection to Vout (+). Record the resulting output voltage in Table 3-1. If using a 4-20 mA calibrated meter, set the multimeter to read current and connect the meter to read the mA signal in your connected loop. Record the resulting current output in Table 3-1.
8. Repeat Step 6 and Step 7 to record the results of the remaining four bridge voltage validation points in Table 1. Compare the values recorded in Table 3-1. Indicated values must be within the flow meter's stated accuracy shown on the Calibration Certificate.
9. When data collection is complete, turn off power to the flow meter. Disconnect the multimeter from the flow meter terminal block.

- Place the J1 Cal/Run jumper in the RUN position. Make sure the jumper is securely in place before resuming flow meter operation. Replace the flow meter cover(s).

Calibration Certificate Values				Validation Test Results			
Sample Point	Bridge Voltage	Indicated Flow	Output (V or mA)	Indicated Flow (LCD)	Flow Meter Stated Accuracy	Output (V or mA)	Flow Meter Stated Accuracy
0%							
25%							
50%							
75%							
100%							

Table 3-1. Electronics Validation Results

### Sensor Validation Procedure



#### Caution!

Do not power the flow meter with the sensor jumper disconnected. This could cause overheating of the sensors and/or damage to the electronics.

1. Locate the  $R_0$  temperature (measured resistance at  $0^\circ\text{C}$ ) value and the Alpha value shown on the Calibration Certificate supplied with the flow meter.
2. **Turn off power to the flow meter. Allow a 6 minute cool-down before continuing.**
3. Remove the cover of the flow meter enclosure to access the sensor connection points. Remove the four-position jumper from J5, J6, J7 and J8 (see below for location).

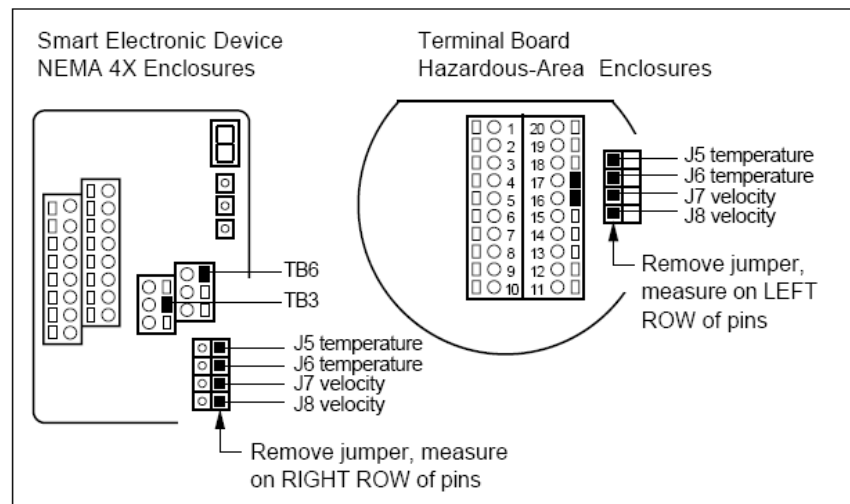

Figure 3-4. Sensor Validation Component Locations

4. Set the multimeter to read Ohms in the 200 Ohm range. Connect TB3 and TB6 on NEMA 4X enclosures or TB17 and TB18 on Hazardous-Area enclosures. Measure the cable resistance between the terminals. Record the resistance (in Ohms) in Column 1 of Table 3-2.
5. Set the multimeter to read Ohms in the 2K range. Connect to terminals of J5 and J6 (temperature sensor). Measure the resistance between J5 and J6. Record the temperature sensor resistance (in Ohms) in Column 2 of Table 3-2.
6. Set the multimeter to read in the 200 Ohm range. Connect the multimeter to terminals of J7 and J8 (velocity sensor). Measure the resistance between J7 and J8 and record the velocity sensor resistance (in Ohms) in Column 2 of Table 3-2.

7. Calculate  $R_{\text{final}}$  by subtracting Column 1 from Column 2. Enter the value in Column 3 of Table 3-2.
8. Use the measured resistance values and the  $R_0$  and Alpha  $R_0$  values from the Calibration Certificate to calculate the temperature for each sensor as follows:

$$T = \frac{R - R_0}{\text{Alpha} \times R_0}$$

Where

T = degrees Celsius

R = measured sensor resistance

$R_0$  = resistance at 0° C (from the Calibration Certificate)

Alpha = value unique to each sensor (from the Calibration Certificate)

9. Compare the results recorded in Column 4 of Table 3-2. The sensors are validated if they are within 10 degrees Celsius of each other.
10. Disconnect the multimeter and replace the four-position jumper on the sensor terminals. **Make sure the jumper is securely in place before applying power.** Replace cover.

Column 1	Column 2	Column 3	Column 4
Cable Resistance	Temperature Sensor Resistance	$R_{\text{final}}$	T (from equation)
Cable Resistance	Velocity Sensor Resistance	$R_{\text{final}}$	T (from equation)

Table 3-2. Sensor Validation Results

## Chapter 4 Troubleshooting and Repair

### Troubleshooting the Flow Meter

**Warning!**

Before attempting any flow meter repair, verify that the line is not pressurized.

Always remove main power before disassembling any part of the mass flow meter.

Begin hardware troubleshooting by verifying the following facilities issues are correct. These areas impact system operation and must be corrected prior to performing any flow meter inspections.

1. Verify the incoming power to the flow meter is present and of the correct voltage and polarity.
2. Check the flow meter wiring for correct connections as described in Chapter 2.
3. Verify the flow meter is installed with the correct number of upstream pipe diameters as shown on page 2-2.
4. Verify the flow direction indicator is correctly aligned pointing downstream of flow.
5. Make sure there are no leaks in the line being measured.

After verifying the factors above, follow the troubleshooting procedures outlined on the next page. If you need to return the flow meter to the factory, see page 4-3 for return shipping instructions.

#### Flow Meter Calibration

Sierra Instruments maintains a fully-equipped calibration laboratory. All measuring and test equipment used in the calibration of Sierra meters are traceable to NIST standards. Sierra is ISO-9001 registered and conforms to the requirements of ANSI/NCSL-Z540 and ISO/IEC Guide 25. If the flow body or electronics have been damaged or you simply want to have the flow meter re-calibrated, contact the factory for return shipping instructions. Calibration must be performed by qualified personnel using NIST-traceable equipment.

<b>Problem</b>	<b>Possible Cause</b>	<b>Solution</b>
<b>Velocity measurement is erratic or fluctuating</b>	Very erratic or non-uniform flow	Follow installation requirements shown in Chapter 2
	Moisture present in gas flow	Install a water trap or filter upstream of the flow meter sensor
	Flow conditioning plates are not upstream of the sensor	Correct flow meter orientation
	Sensor component broken	Return to factory for replacement
	Malfunction in system electronics	Return to factory for evaluation
	Ground loop	Check wiring, see Chapter 2
<b>Velocity measurement seems too high or low</b>	Sensor assembly not aligned correctly to flow	Correct alignment with the flow indicator pointing downstream in the direction of flow
	Flow conditioning plates are not upstream of the sensor	Correct flow meter orientation
<b>No response to flow from sensor assembly</b>	No power	Turn on power to the flow meter
	Low flow cutoff setting too high	Correct low flow cutoff programming using the Smart Interface software.
	Flow rate below meter's minimum flow rating	Contact factory for instructions
	Flow has exceeded the maximum range of the flow meter	Set the user full scale to equal the factory full scale  Reduce flow below the maximum range shown on the meter's nameplate or contact the factory for re-calibration advice
	Sensor failure	Return to factory for evaluation
	Printed circuit assembly defective	Return to factory for evaluation



## Returning Equipment to Factory

### *Factory Calibration—All Models*

Sierra Instruments maintains a fully-equipped calibration laboratory. All measuring and test equipment used in the calibration of Sierra transducers are traceable to NIST Standards. Sierra is ISO-9001 registered and conforms to the requirements of ANSI/NCSL-Z540 and ISO/IEC Guide 25.

### ***Instructions for Returning Your Instrument for Service***

The following information will help you return your instrument to Sierra Instruments' Factory Service Center and will ensure that your order is processed promptly. Prices may vary depending on the flow range, type of gas and operating pressure of your unit. To request detailed pricing, contact your local Sierra Instruments distributor or contact one of our offices directly. Our expedite fees are: three-day turnaround 25%, two-day turnaround 40%.

### ***Please follow these easy steps to return your instrument for factory service:***

Obtain a Return Materials Authorization (RMA) number from the Sierra Instruments website at <http://www.sierrainstruments.com/rma/login.php>

If you require service beyond calibration, but do not know which service(s) will be required, describe the symptoms as accurately as possible on the RMA form.

Pack your instrument carefully. Use the original packaging and foam or bubble wrap (packing peanuts NOT recommended) and include a copy of the RMA form (complete with Sierra supplied RMA number) with the unit(s).

Ship the unit(s) to the following address:

**Sierra Instruments, Inc.  
Attention: Factory Service Center  
5 Harris Court, Building L  
Monterey, CA 93940 USA  
RE: RMA# (your number)**

# Appendix A 780S Product Specifications

2

## DIMENSIONAL SPECIFICATIONS

1/4-inch NPT—Front View (E2)

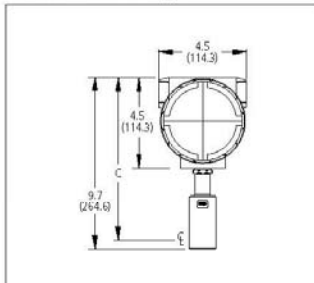

1/4-inch NPT—Side View (E2)

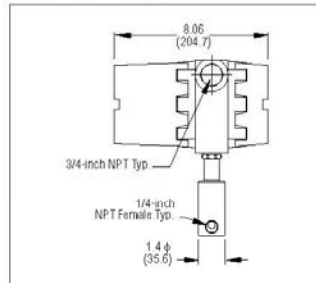

Sizes for NPT

Sizes For NPT			
Size	C	L1	L2
1/4-inch	8.40 (213.4)	—	—
1/2-inch	6.90 (175.3)	2.20 (55.9)	6.50 (165.1)
3/4-inch	6.90 (175.3)	2.20 (55.9)	7.00 (177.8)
1-inch	9.10 (228.6)	1.50 (38.1)	3.50 (88.9)
1.5-inch	9.40 (238.8)	2.25 (57.2)	5.25 (133.4)
2-inch	10.20 (259.1)	3.50 (88.9)	7.50 (190.5)
3-inch	11.20 (284.5)	4.00 (101.6)	10.00 (254)
4-inch	11.20 (284.5)	4.00 (101.6)	12.00 (304.8)
6-inch	12.20 (309.9)	6.00 (152.4)	18.00 (457.2)
8-inch	13.20 (335.3)	8.00 (203.2)	24.00 (609.6)

1/2-inch and 3/4-inch NPT—Front View (E2)

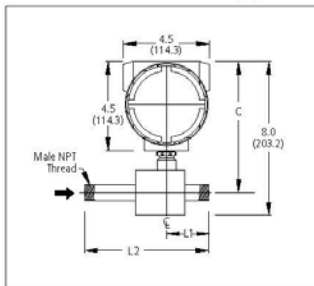

1/2-inch and 3/4-inch NPT—Side View (E2)

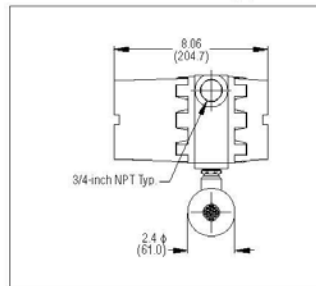

1-inch Through 8-inch NPT—Front View (E2)

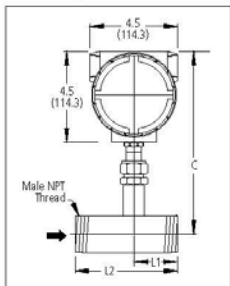

1-inch Through 8-inch NPT—Side View (E2)

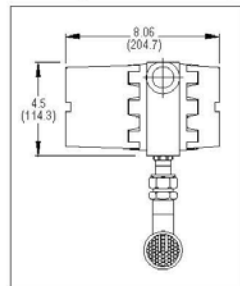

1-inch to 8-inch NPT—Front/Side View (EN2)

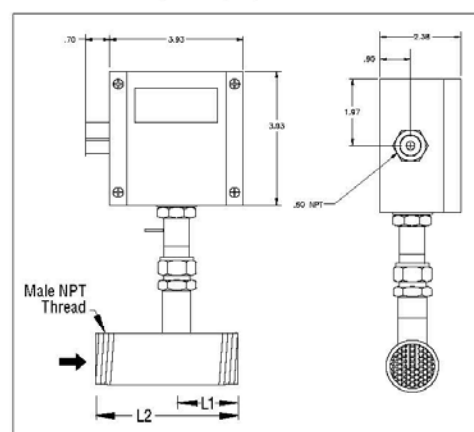

1/2 and 3/4-inch 150 lb Flange—Front View (E2)

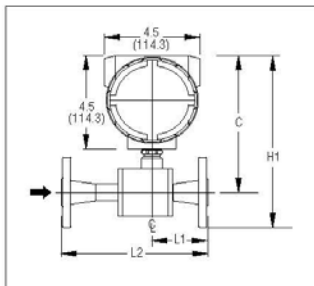

1/2 and 3/4-inch 150 lb Flange—Side View (E2)

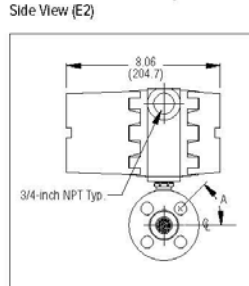

Sizes for 150 lb ANSI Flange

Sizes For 150 Lb Ansi Flanges					
Size	H1	C	L1	L2	A
1/2-inch	7.79 (197.9)	6.94 (176.3)	2.60 (66.0)	6.95 (176.5)	45°
3/2-inch	7.79 (197.9)	6.94 (176.3)	2.78 (70.6)	7.56 (192.0)	45°

All dimensions are inches. Millimeters are in parentheses. All drawings have a +/- .25-inch (6.4 mm) tolerance. Certified drawings are available on request.

**DIMENSIONAL SPECIFICATIONS**

1" Through 8" 150 lb Flange—Front View (E2)

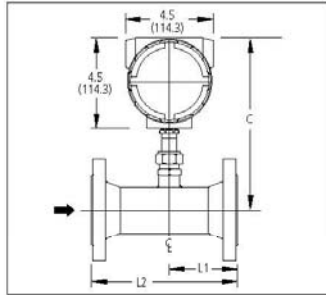

1" Through 8" 150 lb Flange—Side View (E2)

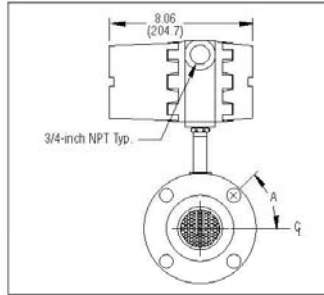

DN Flange—Front View (E2)

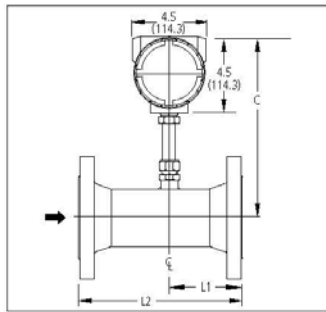

DN Flange—Side View (E2)

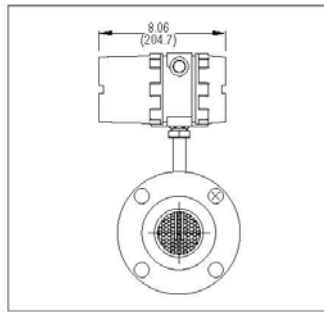

Sizes For 150 Lb Ansi Flanges				
Size	C	L1	L2	A
1-inch	9.10 (238.8)	3.60 (91.4)	7.40 (188.0)	45°
1.5-inch	9.40 (238.8)	3.80 (96.5)	7.56 (192.0)	45°
2-inch	10.20 (259.1)	3.50 (88.9)	7.50 (190.5)	45°
3-inch	11.20 (284.5)	4.00 (101.6)	12.00 (304.8)	22.5°
4-inch	11.20 (284.5)	4.00 (101.6)	12.00 (304.8)	22.5°
6-inch	12.20 (309.9)	6.00 (152.4)	18.00 (457.2)	22.5°
8-inch	13.20 (353.3)	8.00 (203.2)	24.00 (609.6)	22.5°

NEMA 4X Enclosure - Front View (EN2)

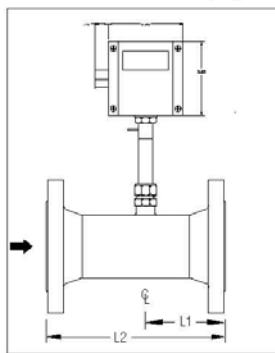

NEMA 4X Enclosure—Side View (EN2)

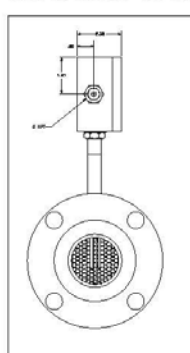

Sizes For PN16 DL Flanges			
Size	C	L1	L2
DN50	10.70 (271.8)	3.34 (84.8)	7.10 (180.3)
DN80	10.50 (266.7)	4.14 (105.2)	10.20 (259.1)
DN100	10.60 (269.2)	4.57 (116.1)	12.60 (320.0)
DN150	12.40 (315.0)	6.77 (172.0)	18.90 (480.1)
DN200	14.50 (368.3)	8.47 (215.1)	24.00 (619.8)

Remote Mounted with Junction Box (E4)

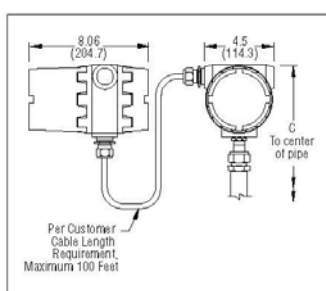

Remote Mounted with Junction Box (EN4)

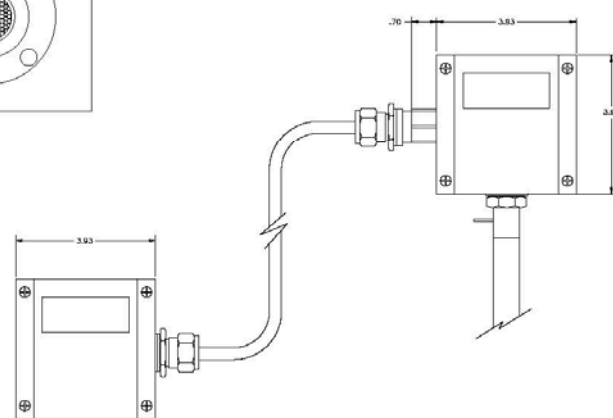

All dimensions are inches. Millimeters are in parentheses. All drawings have a +/- .25-inch (6.4 mm) tolerance. Certified drawings are available on request.

4

Sizes For Remote Mounted	
Size	C
1/4-inch	8.4 (198.1)
1/2-inch	6.9 (175.3)
3/4-inch	6.9 (175.3)
1-inch	9.10 (231.1)
1.5-inch	9.40 (238.8)
2-inch	10.20 (259.1)
3-inch	11.20 (284.5)
4-inch	11.20 (284.5)
6-inch	12.20 (309.9)
8-inch	13.20 (335.3)

**PERFORMANCE SPECIFICATIONS**

**Accuracy**

+/- 1% of reading + 0.5 % of full scale

**Repeatability**

+/- 0.2% of full scale

**Temperature Coefficient**

+/- 0.02% of reading per °F within +/- 50° F of customer specified conditions

+/- 0.03% of reading per °F within +/- 50° F to 100° F of customer specified conditions

+/- 0.04% of reading per °C within +/- 25° C of customer specified conditions

+/- 0.06% of reading per °C within +/- 25° C to 50° C of customer specified conditions

**Pressure Coefficient**

.02% per psi for air, consult factory for other gases

**Response Time**

One second to 63% of final velocity value

**OPERATING SPECIFICATIONS**

**Gases**

Most gases compatible with 316 L stainless steel

**Gas Pressure (2 limitations)**

Mechanical design pressure:

Compression fittings: 500 psig (34.5 barg)

150 lb flange or PN16 DN (-40° F to 100° F): 230 psig (15.9 barg)

150 lb flange or PN16 DN (250° F): 185 psig (12.8 barg)

150 lb flange or PN16 DN (450° F): 155 psig (10.7 barg)

NPT (-40° F to 250° F): 500 psig (34.5 barg)

**PERFORMANCE SPECIFICATIONS**

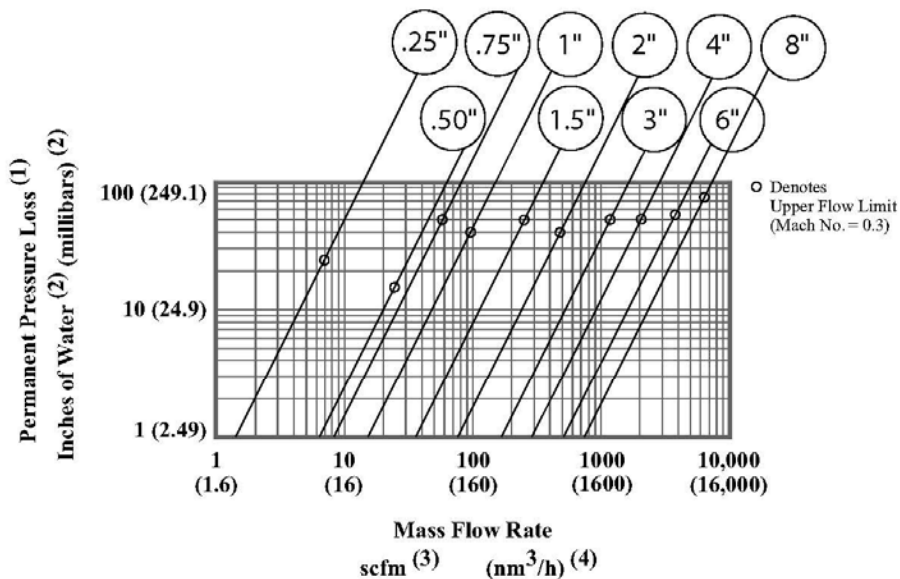

**Notes:**

(1) For air and nitrogen at 20 °C temperature and 1 atmosphere pressure.

(2) 1 inch of water at 60 °F= 0.0361 psi.  
1 millibar = 0.001 bar = 100 pascal = 0.0145 psi.

(3) At base conditions of 21.1 °C temperature and 1 atmosphere pressure.

(4) At base conditions of 0 °C temperature and 1 atmosphere pressure.

(5) Built-in flow conditioner consists of two separate perforated plates in series.

**OPERATING SPECIFICATIONS (CONTINUED)**

**Gas & Ambient Temperature**

Gas . . . . . -40° F to 350° F (-40° C to 177° C)  
 Ambient . . . . . -40° F to 120° F (-40° C to 50° C)

**Leak Integrity**

5 X 10<sup>-9</sup> cc/sec of helium maximum

**Power Requirements**

18 to 30 VDC (regulated), 625 mA maximum  
 100 to 240 VAC, 50/60 Hz, 15 watts maximum  
 625 mA maximum operating current at 24 VDC and full scale flow  
 Maximum in rush current of 2 Amps at 24 VDC  
 Consult factory for other conditions

**Output Signal**

Linear 0–5 VDC or 0-10 VDC, 1000 ohms minimum load resistance or  
 Linear 4–20 mA proportional to mass flow rate,  
 700 ohms maximum resistance power supply dependent  
 User-selectable: Active non-galvanically separated or Passive  
 galvanically separated (loop power required)  
 See Digital Communications options below

**Alarms**

Hard contact user-adjustable high and low  
 Dead band adjustable with Smart Interface™ software  
 Relay ratings . . . . . Maximum 400 VDC or VAC (peak), 140 mA

**Displays**

Alphanumeric 2 x 12 digit backlit LCD  
 Adjustable variables via on-board switches (password protected)  
 or with Smart Interface™ software  
 Adjustable variables Full scale (50 to 100 %)  
 Time Response (1 to 7 seconds)  
 Correction factor setting (0.5 to 5)  
 Zero and span  
 High and low alarm settings

**Totalizer**

Seven digits (9,999,999) in engineering units  
 Resettable by software, on-board switches or external magnet

**Software**

Smart Interface™ Windows®-based software  
 Minimum 8 MB of RAM, preferred 16 MB of RAM  
 RS-232 communication

Additional features Alarm dead band adjustment  
 Zero cut-off adjustment  
 Linearization adjustment  
 Save / Load configurations  
 Fully guided flow meter validation

**DIGITAL COMMUNICATIONS OPTIONS**

Pulse (1Hz max, not available with E2-NR)  
 Modbus RTU (not available with P3 option)  
 Profibus DP (available E2/E4-P2 configuration only)  
 HART universal commands (available E2/E4-P2 configuration only)  
 Foundation Fieldbus (available E2/E4-P2 configuration only)

**PHYSICAL SPECIFICATIONS**

**Wetted Materials**

316L stainless steel  
 Carbon steel flow bodies available in some sizes

**Enclosure**

Hazardous-Area Location Enclosure (IP66) and NEMA 4X (IP65) are  
 powder-coated cast aluminum

**Electrical Connections**

Two 3/4 inch NPT . . . . .Hazardous-Area Location Enclosure (IP66)  
 One 1/2 inch NPT . . . . .NEMA 4X Enclosure (IP65)

**Piping Requirements**

Straight Pipe Length Requirements at 1 ATM			
Piping Condition	780S FlatTrak™		Orifice Plate (3)
	Upstream	Downstream	
Single 90° Elbow or T-Piece	1D	0D	28D
Reduction (4:1)	3D	0D	14D
Expansion (4:1)	3D	0D	30D
After Control Valve	3D	0D	32D
Two 90° Elbows (In Same Plane)	3D	0D	36D
Two 90° Elbows (Different Plane)	5D	0D	62D

Notes: (1) Number of diameters (D) of straight pipe required between upstream disturbance and the flow meter.  
 (2) Number of diameters (D) of straight pipe required downstream of the flow meter.  
 (3) For comparison purposes only. Table shows number of diameters (D) of upstream straight pipe length required for an ISO Standard 5167 Orifice Plate with a Beta Ratio of 0.7.  
 (4) Consult factory for pressure effects.

**Certifications**

CE (All enclosures)  
 CSA (Explosion proof for Class I, Division 1, Groups B, C, D)  
 ATEX ( II 2 GD Ex d IIC T6 ... T2; IP 66 T70 °C ... T280 °C )  
 FM (Explosion proof for Class I, Division 1, Groups B, C, D; dust-ignition proof for Class II, III, Division 1, Groups E, F, G)  
 IP65, NEMA 4X T6 -40° C to 70° C ambient  
 PED optional

® Viton, Neoprene, Kalrez, and Teflon are registered trademarks of DuPont. Windows and Excel are registered trademark of Microsoft.



ORDERING THE 780S

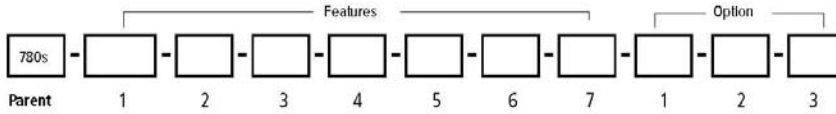

Instructions: To order a 780S please fill in each number block by selecting the codes from the corresponding features below and following pages.

Parent Model Number	
<b>780S</b>	FlatTrak™ In-line Mass Flow Meter with Flow Conditioner. All 316 stainless steel construction. UHP 5-10 RA available. 18-30 VDC or 100-240VAC input power with 3/4-inch diam 316SS probe. Includes "Smart Electronics" with PC configuration software. Calibration temperatures up to 350°F (176°C) and pressure to 500 psig (34.5 barg). CE, FM, CSA, ATEX approvals. Linear 0-5 VDC or 4-20 mA output signals. Lifetime warranty on non-UHP Fast Response (FR) sensor

Note: The following lists standard product/pricing. Sierra will work with you for special requests. Please submit your request using the RFQ/Specials tab in this price list.

Feature 1: Approvals	
<b>NAA</b>	Non-agency approved meter
<b>ATEX</b>	780S with II 2 GD Ex d IIC T2...T6 ATEX Approval. Requires E2 or E3 enclosure. Note: ATEX units have circuit energy limitations that limit maximum flows to approx. 50% of non-ATEX units. Consult gas tables for details.
<b>FM</b>	780S with FM approval. Requires E2 or E4 enclosure
<b>CSA</b>	780S with CSA approval. Requires E2 or E4 enclosure

Feature 2: Body Size-NPT*	
<b>N1</b>	1/4-inch NPT Female 316SS
<b>N2</b>	1/2-inch NPT Male 316SS
<b>N3</b>	3/4-inch NPT Male 316SS
<b>N4</b>	1-inch NPT Male 316SS
<b>N5</b>	1.5-inch NPT Male 316SS
<b>N6</b>	2-inch NPT Male 316SS
<b>N7</b>	3-inch NPT Male 316SS
<b>N8</b>	4-inch NPT Male 316SS
<b>N9</b>	6-inch NPT Male 316SS
<b>N10</b>	8-inch NPT Male 316SS

Feature 2: Body Size-ANSI 150*	
<b>F2</b>	1/2-inch ANSI class 150 flange 316SS
<b>F3</b>	3/4-inch ANSI class 150 flange 316SS
<b>F4</b>	1-inch ANSI class 150 flange 316SS
<b>F5</b>	1.5-inch ANSI class 150 flange 316SS
<b>F6</b>	2-inch ANSI class 150 flange 316SS
<b>F7</b>	3-inch ANSI class 150 flange 316SS
<b>F8</b>	4-inch ANSI class 150 flange 316SS
<b>F9</b>	6-inch ANSI class 150 flange 316SS
<b>F10</b>	8 inch ANSI class 150 flange 316SS

Feature 2: Body Size-PN 16*	
<b>FD6</b>	DN50, PN16, DIN flange
<b>FD7</b>	DN80, PN16, DIN flange
<b>FD8</b>	DN100, PN16, DIN flange
<b>FD9</b>	DN150, PN16, DIN flange
<b>FD10</b>	DN200, PN16, DIN flange

Feature 2: Body Size-PN 40	
<b>GD4</b>	DN25, PN40, DIN flange
<b>GD5</b>	DN40, PN40, DIN flange
<b>GD6</b>	DN50, PN40, DIN flange
<b>GD7</b>	DN80, PN40, DIN flange
<b>GD8</b>	DN100, PN40, DIN flange
<b>GD9</b>	DN150, PN40, DIN flange
<b>GD10</b>	DN200, PN40, DIN flange

Note: Carbon steel, Hastelloy®, PVC, and Kynar flow bodies are available. Consult Factory for information.

ORDERING THE 780S (continued)

Feature 3: Electronics Enclosure	
E2	Hazardous-area location enclosure (IP66). Mounted directly on probe
E3 ( )	Remote hazardous-area location enclosure (IP66). Specify cable length in parenthesis. Maximum 200 feet (61m) (IP66) housing mounted up to 200 feet (61m) from flow body; includes strain relief on end of probe and mounting bracket. Specify cable length between brackets
E4 ( )	Remote hazardous-area location Enclosure (IP66) with junction box specify cable length in parenthesis. Maximum 200 feet (61m) (IP66) housing mounted up to 200 feet (61m) from flow body; includes (IP66) junction box mounted on probe and mounting bracket (304SS) Specify cable length between brackets
EN2	NEMA 4X (IP65) Enclosure. Mounted directly on probe.
EN4 ( )	Remote NEMA 4X (IP65) enclosure with junction box. Specify cable length in parenthesis. Maximum 200 feet (61m). Mounted up to 200 feet (61m) away from the probe with junction box mounted on probe. Includes remote electronics enclosure mounting bracket and 1/2-inch Female NPT connection. Specify cable length between brackets

Feature 4: Input Power	
P2	18–30 VDC
P3	100–240 VAC. Not available with EN enclosures.

Feature 5: Output	
V1	0–5 VDC, linear
V3	0-10 VDC, linear
V4	4-20 mA, linear

Feature 6 : Display	
NR	No Readout
DD	Digital display. 2 x 12 digit, backlit, LCD display indicates flow rate and totalized mass in engineering units. Simplifies configuration settings and provides system status information
DD-NRT	Totalizer cannot be reset in the field.

Feature 7: Gas	
0	Air
1	Argon
2	Carbon dioxide
3	Chlorine <sup>1</sup>
4	Digester gas
5	Digester gas <sup>1</sup>
6	Helium
7	Hydrogen
7C	Hydrogen <sup>1</sup>
8	Methane
9	Methane <sup>1</sup>
10	Nitrogen
11	Oxygen <sup>1</sup>
12	Propane
13	Propane <sup>1</sup>
14	Ammonia <sup>1</sup>
99	Other--Consult Factory Gas Table

<sup>1</sup>Correlation calibration - consult Gas Table for accuracy.  
Note: Consult Product Data Sheet for flow rate, pressure, and temperature limits.

Option 1 : Digital Communications	
Pulse	Totalizer pulse output (Only available with E2/E3/E4 enclosures WITH DD. Available on ALL EN2 Enclosures)
DP1	Profibus DP using an M12 connector (available E2/ E4–P2, NAA only) with full device description
DP2	Profibus DP using a 2-wire terminal block connection (available E2/ E4–P2 config only) with full device description; FM approval available
MB	Modbus RTU with full device description (P2 only); ATEX and FM approvals available
FF	Foundation Fieldbus with full device description (available E2/ E4–P2 config only); FM approval available
HART	HART universal variables; flow totalizer, K-factor, user full scale, and instantaneous flow (available E2-P2 /E4-P2) config only). FM approval available.

Note: All except Pulse require DC power (P2).

Option 2: Certificates	
MC	Material certificates--US Mill certs on all wetted parts
PED	Manufactured according to PED directive
CC	Certificate of conformance
NACE	NACE certificate for sour gas
LT	Leak test certificate
PT	Pressure test certificate

Option 3: O2 Cleaning	
O2C	O2 Cleaning. Meters up to 4 inches (DN100). Includes certification. Product cleaned for O2 service. Inspected with Ultra-Violet light, double-bagged prior to shipment.

Note: Consult factory for O2 Cleaning of meters over 4-inches (DN100).

# Appendix B 760S Product Specifications

2

## DIMENSIONAL SPECIFICATIONS - ELECTRONIC & PROBE

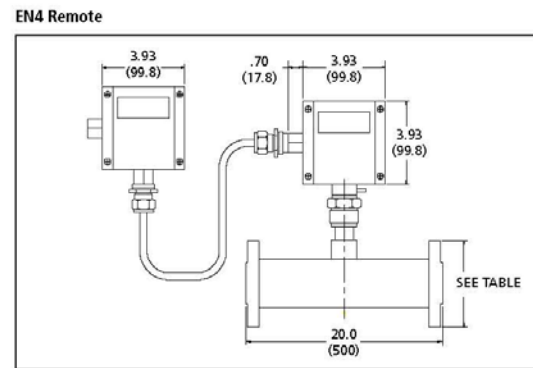
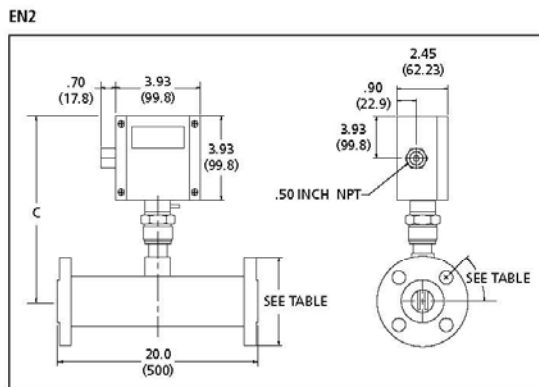
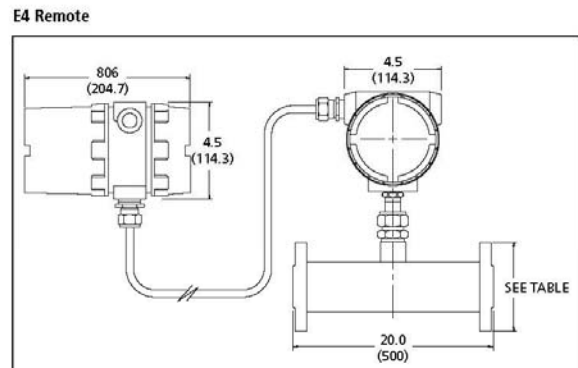
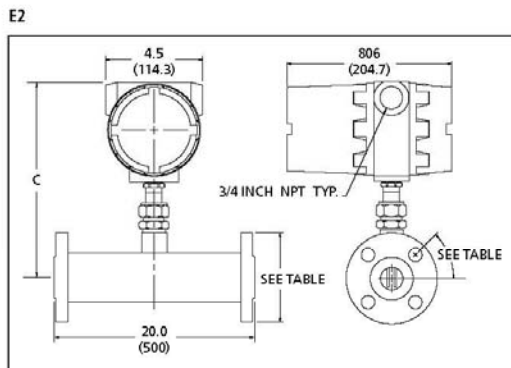

## DIMENSIONAL SPECIFICATIONS - FLOW BODY

Note: Face to face is 20" (500mm)

Kynar Flow Body					
Size	Flange Diameter	Number/ Diameter of Holes	Bolt Circle Diameter	C E2	C EN2
1" (25)	4.25" (106.25)	4.62 (15.5)	3.12 (78)	10.54 (267.72)	9.97 (253.24)
1.5" (37.5)	5.0" (125)	4.62 (15.5)	3.88 (97)	11.60 (294.64)	11.02 (279.91)
2" (50)	6.0" (150)	4.75 (18.75)	4.75 (118.75)	10.62 (269.75)	10.05 (255.27)
3" (75)	7.25" (181.25)	4.75 (18.75)	6.0 (150)	11.62 (295.15)	11.05 (280.67)
4" (100)	9.0" (225)	4.75 (18.75)	7.5 (187.5)	11.62 (295.15)	11.05 (280.67)

## PIPING REQUIREMENTS

Minimum required straight piping before the flow meter. NOTE: Unlike the Sierra 760S, the 760S Series does not contain built-in flow conditioners. Straight piping before the flow meter is therefore very important for proper operation. See table below.

Piping Condition 760S	
Single 90° Elbow or T-Piece	28D
Reduction (4:1)	14D
Expansion (4:1)	30D
After Control Valve	32D
Two 90° Elbows (In Same Plane)	36D
Two 90° Elbows (Different Planes)	62D

Note: 5D Required after flow meter



## SPECIFICATIONS

3

## OPERATING SPECIFICATIONS

**Gases**

Dry Chlorine Gas (contact Sierra for other gases)

Gas Pressure limitations: up to 120 psig (8 barg)

Gas Temperature limitations: 15° F to 212° F (-9° C to 100° C)

**Mechanical design pressure:**

Hastelloy® C-276 Compression fittings: 500 psig (34.5 barg)

150 lb flange and Kynar body (-40° F to 100° F): 230 psig (15.9 barg)

**Pressure Drop**

Negligible

## PERFORMANCE SPECIFICATIONS

**Accuracy**

+/- 5.0 % of full scale (chlorine correlation)

**Repeatability**

+/- 0.2% of full scale

**Temperature Coefficient**

± 0.02% of reading per °F within ± 50° F of customer specified conditions

± 0.03% of reading per °F within ± 50° F to 100° F of customer specified conditions

± 0.04% of reading per °C within ± 25° C of customer specified conditions

± 0.06% of reading per °C within ± 25° C to 50° C of customer specified conditions

**Pressure Coefficient**

.02% per psi (.07 barg)

**Response Time**

One second to 63% of final velocity value

**Gas & Ambient Temperature**

Gas . . . . . 15° F to 212° F (-9° C to 100° C)

Ambient . . . . . -5° F to 120° F (-20° C to 50° C)

**Leak Integrity**

5 X 10-4 cc/sec of helium maximum

**Power Requirements**

18 to 30 VDC (regulated), 625 mA maximum

100 to 240 VAC, 50/60 hz, 15 watts maximum

**Output Signal**

Linear 4–20 mA proportional to mass flow rate,

700 ohms maximum resistance power supply dependent

User-selectable . . . Active non-galvanically separated or

Passive galvanically separated (loop power required)

MODBUS RTU (optional)

**Alarms**

Hard contact user-adjustable high and low

Dead band adjustable with Smart Interface™ software

Relay ratings . . . . . Maximum 400VDC or VAC (peak), 140 mA

## PERFORMANCE SPECIFICATIONS continued

**Displays**

Alphanumeric 2 x 12 digit backlit LCD

Adjustable variables via on-board switches (password protected) or with Smart Interface™ software.

Adjustable variables . . . . . Full scale (50 to 100 %)

. . . . . Time Response (1 to 7 seconds)

. . . . . Correction factor setting (0.5 to 5)

. . . . . Zero and span

. . . . . High and low alarm settings

**Totalizer**

Seven digits (9,999,999) in engineering units

Resettable by software, on-board switches

**Software**

Smart Interface™ Windows®-based software

Minimum 8 MB of RAM, preferred 16 MB of RAM RS 232

communication

Additional features . . . . . Alarm dead band adjustment

. . . . . Zero cut-off adjustment

. . . . . Linearization adjustment

. . . . . Save / Load configurations

. . . . . Fully guided flow meter validation

## PHYSICAL SPECIFICATIONS

**Wetted Materials**

Flow Body: Kynar® polyvinylidene fluoride resin

Sensor Probe: 6" Hastelloy® C-276 probe and 1" Swagelok®

Hastelloy® C-276 NPT compression fitting to mate with the

Kynar® PVDF flow body.

**Enclosure**

NEMA 4X (IP65) powder-coated cast aluminum

IP66 explosion proof

**Electrical Connections**

One 1/2 inch NPT . . . NEMA 4X Enclosure (IP65)

Two 3/4 inch NPT on explosion proof

**Body Specifications**

K4: 1" ANSI 150 lb Flange-Kynar Flow body with 6" Hastelloy probe (max flow 20 scfm, 32 nm3/hr)

K5: 1.5" ANSI 150 lb Flange-Kynar Flow body with 6" Hastelloy probe(max flow 45 scfm, 71 nm3/hr)

K6: 2" ANSI 150 lb Flange-Kynar Flow body with 6" Hastelloy probe (max flow 75 scfm, 118 nm3/hr)

K7: 3" ANSI 150 lb Flange-Kynar Flow body with 6" Hastelloy probe (max flow 175 scfm, 276 nm3/hr)

K8: 4" ANSI 150 lb Flange-Kynar Flow body with 6" Hastelloy probe (max flow 300 scfm, 473 nm3/hr)

Note: smaller bodies are NOT available.

For larger bodies >4" submit RFQ.

4

**ORDERING INFORMATION**

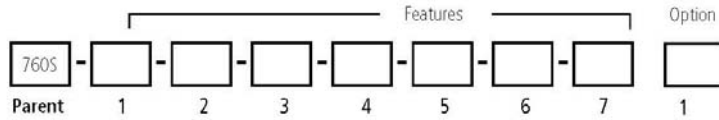

Instructions: To order a 760S please fill in each number block by selecting the codes from the corresponding features below and following pages.

Parent Number	
760S	Chlorine-Trak™ In-line Mass Flow Meter. Specially designed flow body manufactured from Kynar® polyvinylidene fluoride resin. 18-30 VDC or 100-240VAC input power with 3/4-inch diameter 6-inch long Hastelloy® probe. Includes "Smart Electronics" with PC configuration software. Application limits: 15°F to 212°F (-9°C to 100°C) and 120 psig (8.3 barg). CE approvals. Linear 0-5 VDC or 4-20 mA output signals. Modbus optional.

Feature 1: Approvals	
NAA	Non-Agency Approved Meter

Feature 2: Body Size-ANSI 150	
K4	1-inch ANSI class 150 Flange-Kynar flow body with 6-inch Hastelloy probe (max flow 100 scfm, 157 nm3/hr)
K5	1.5-inch ANSI class 150 Flange-Kynar flow body with 6-inch Hastelloy probe (max flow 245 scfm, 386 nm3/hr)
K6	2-inch ANSI class 150 Flange-Kynar flow body with 6-inch Hastelloy probe (max flow 410 scfm, 646 nm3/hr)
K7	3-inch ANSI class 150 Flange-Kynar flow body with 6-inch Hastelloy probe (max flow 917 scfm, 1447 nm3/hr)
K8	4-inch ANSI class 150 Flange-Kynar flow body with 6-inch Hastelloy probe (max flow 1597 scfm, 2519 nm3/hr)

Note: Smaller bodies are not available. For larger bodies > 4 inch submit RFQ. Application limits: 15°F -212°F (-9°C to 100°C); up to 120 psig (8 barg)

Feature 3: Enclosure	
E2	Hazardous-area location enclosure (IP66). Mounted directly on probe.
E4 ( )	Remote hazardous-area location enclosure (IP66) with junction box, specify cable length in parenthesis. Maximum 200 feet (61m) (IP66) housing mounted up to 200 feet (61m) from flow body; includes (IP66) junction box mounted on probe and mounting bracket (304SS) Specify cable length between brackets
EN2	NEMA 4X (IP65) Enclosure. Mounted directly on probe.
EN4 ( )	Remote NEMA 4X (IP65) Enclosure with Junction Box. Specify cable length in parenthesis. Maximum 200 feet (61m). Mounted up to 200 feet (61m) away from the probe with junction box mounted on probe. Includes remote electronics enclosure mounting bracket and 1/2-inch Female NPT connection. Specify cable length between brackets

Feature 4: Input Power	
P2	18-30 VDC
P3	100-240 VAC. Not available with EN enclosures

Feature 5: Output Power	
V1	0-5 VDC, linear
V3	0-10 VDC, linear
V4	4-20 mA, linear

Feature 6: Display	
NR	No readout
DD	Digital display. 2 x 12 digit, backlit, LCD display indicates flow rate and totalized mass in engineering units. Simplifies configuration settings and provides system status information
DD-NRT	Totalizer cannot be reset in the field.

Feature 7: Gas	
3	Chlorine (correlation: Accuracy +/- 5.0%)
99	Other

Application limits: See flow body for flow rate limits; 15° - 90°F (-9° to 32°C); up to 120 psig (8.3 barg). +/-5% full scale accuracy

Option 1 : Digital Communications	
Pulse	Totalizer pulse output (Only available with E2/E4 enclosures WITH DD. Available on ALL EN2 Enclosures)
DP1	Profibus DP using an M12 connector (available E2/ E4-P2, NAA only) with full device description
DP2	Profibus DP using a 2-wire terminal block connection (available E2/ E4-P2 config only) with full device description
MB	Modbus RTU with full device description (P2 only)
FF	Foundation Fieldbus with full device description (available E2/ E4-P2 config only)
HART	HART universal variables; flow totalizer, K-factor, user full scale, and instantaneous flow (available E2-P2 /E4-P2) config only.

Note: No FM approval with any 760S digital communications options.

SIERRA INSTRUMENTS, NORTH AMERICA • 5 HARRIS COURT, BUILDING L • MONTEREY, CALIFORNIA 93940 • (800) 866-0200 • (831) 373-0200 • FAX (831) 373-4402 • WWW.SIERRAINSTRUMENTS.COM  
 SIERRA INSTRUMENTS, EUROPE • BULMANSWED 2 • 1934RE EGMOND AAN DEN HOEF • THE NETHERLANDS • +31 72 5071400 • FAX: +31 72 5071401  
 SIERRA INSTRUMENTS, ASIA • SECOND FLOOR BUILDING 5 • SENPU INDUSTRIAL PARK • 25 HANGDU ROAD HANGTOU TOWN • PU DONG NEW DISTRICT • SHANGHAI, P.R. CHINA 201316 • +8621 5879 8521/22 • FAX: +8621 5879 8586  
 760S Chlorine E 7118

## Appendix C Warranty Policy

### *Limited Warranty Policy- Register Online*

All Sierra products are warranted to be free from defects in material and workmanship and will be repaired or replaced at no charge to Buyer, provided return or rejection of product is made within a reasonable period but no longer than one (1) year for calibration and non-calibration defects, from date of delivery. To assure warranty service, customers must register their products online on Sierra's website. Online registration of all of your Sierra products is required for our warranty process. Register now at [www.sierrainstruments.com/register](http://www.sierrainstruments.com/register).

### *Lifetime Limited Warranty On Patented Drysense Sensor Technology*

In addition to Sierra's standard one (1) year manufacturing warranty on all instruments produced, Sierra also offers a lifetime warranty on all DrySense™ sensors standard with Sierra models 640S, 670S, 780S, 640i, and 780i instruments sold after January 1, 2010. This warranty does not extend to the Model 620S, the BoilerTrak™, the HT (High Temperature) 640S/780S sensor or the 780S UHP (Ultra High Purity) sensors. Learn more about Sierra's warranty policy at [www.sierrainstruments.com/warranty](http://www.sierrainstruments.com/warranty)